

Figure 1: Vacuum table explode view

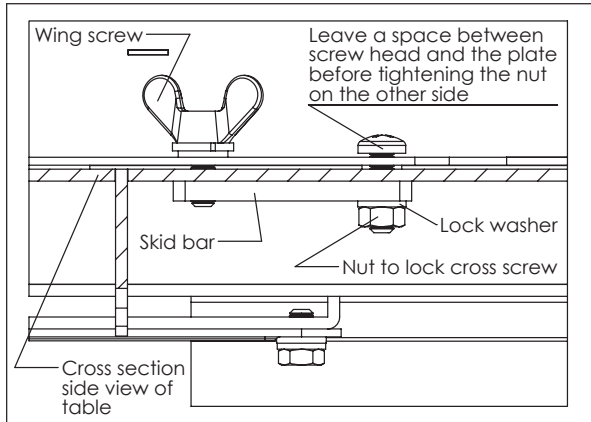

Figure 2: Close-up of skid bar assembly

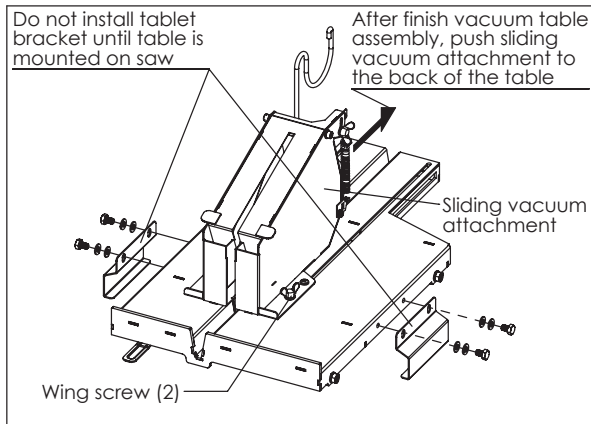

Figure 3: Pushing sliding vacuum attachment to back

Portable 14" Masonry Saw Vacuum Table

READ AND UNDERSTAND ALL INSTRUCTIONS. KNOW THE PRODUCTS APPLICATION, LIMITATIONS, AND POTENTIAL HAZARDS. PROTECT YOURSELF AND OTHERS BY OBSERVING ALL SAFETY INFORMATION. FAILURE TO FOLLOW ALL INSTRUCTIONS LISTED BELOW, MAY RESULT IN SERIOUS PERSONAL INJURY. IN ADDITION MAY DAMAGE AND/OR IMPAIR ITS OPERATION AND VOID THE WARRANTY. RETAIN PRODUCT INSTRUCTIONAL MATERIAL FOR FUTURE REFERENCE.

Note: Unplug power supply before servicing machine.

Note: Raise cutting head and remove blade before installing vacuum table.

Note: When handling this vacuum table for installation/service wear eye protection.

Note: When using this vacuum table, use certified safety equipment:

1. ANSI Z87.1 eye protection
2. ANSI S12.6 (S3.19) hearing protection
3. NIOSH/OSHA/MSHA respiratory protection

Parts List

Item no.	Description	Quantity
1	M6 x 1.0 x 16L Wing screw	2
2	M6 Lock washer	4
3	M6 Washer	4
4	M6 x 1.0 x 15L Cross screw	2
5	Sliding vacuum attachment	1
6	Table sub-assembly	1
7	Tapered spring	1
8	M6 X 1.0 X 30L Socket hex screw	1
9	M6 x 1.0 x Nut	2
10	Skid bar	2
11	M8 X 1.25 X 12L Hex bolt	4
12	M8 Lock washer	4
13	M8 Washer	4
14	Table bracket	2
15	M6 x 1.0 Nylon nut	1

Assemble the Vacuum Table

1. Assemble table as shown in *Fig. 1*. Do not tighten the cross screws (Item #4) that fasten through the table slot to the skid bar as shown in *Fig. 2*. It should be loose before tightening the nut and lock washer from underneath.
2. Loosen the two wing screws and push the entire sliding vacuum attachment to the back as shown in *Fig. 3*.
3. Do not mount brackets and relevant hardware as shown in *Fig. 3* yet.
4. When mounting items #7 and #8 (refer to *Fig. 1*), first rotate the table lock into position as shown in *Fig. 4*. Tighten the socket hex screw enough such that there is about less than 1/2 inch of space between the two washers pressing on the spring. Tighten further as necessary if table lock moves during use. When adjustment is done, tighten the nylon nut (item #15).

Preparing the Masonry Saw to Receive the Vacuum Table

1. Remove items, if mounted on saw already, as shown in *Fig 5*.
 1. Dust tray components
 2. Rear splash guard
 3. Traditional cutting table assembly
 4. Left rubber stop components for cutting table
 5. Water tray

Continue to page 2...

Note: Do not adjust the material being cut or the table while blade is in motion!

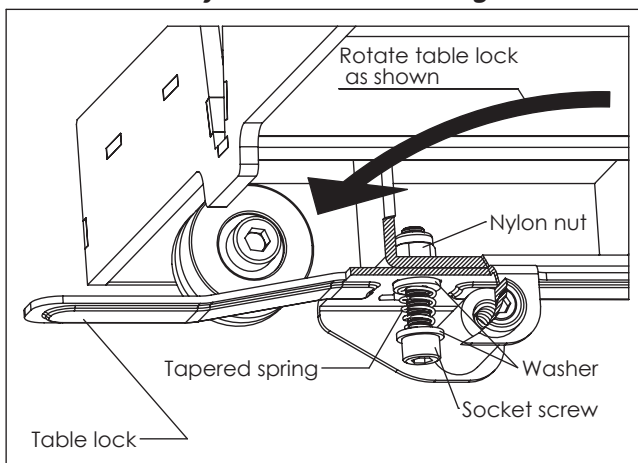

Figure 4: Completing table lock assembly

2. Use a size 10 wrench to loosen the bolt fastening the splash guard on the blade guard. Rotate it up so it no longer hangs down. Retighten the bolt, but do not over tighten.

Mounting the Vacuum Table on the Masonry Saw

1. Install the vacuum table from the back of the saw as shown in Fig. 6. Notice the vacuum hose hook on the sliding vacuum attachment prevents the table from going forward to a certain degree. This is to prevent the blade from cutting the vacuum table. Mount table brackets previously not assembled per Fig. 3 instructions.
2. Notice the two holes on the left rail as shown in Fig. 6. Like the traditional table for wet cutting, the vacuum table can also be locked in these two positions using the table lock.
3. Make sure the blade is almost in the middle of the vacuum inlet of the slide vacuum attachment as shown in Fig. 7. Adjust as necessary by adding or removing the spacers. M8 washers can be used as well.

Using the Vacuum Table

1. Mount the vacuum hose as shown in Fig. 8. Use vacuum hose hook to prevent hose pull-out during use.
2. Raise the vacuum hood by loosening the wing screw in the back next to the vacuum hose hook.
3. Vacuum table can be used for repetitive chop cutting as shown in Fig. 9. Table lock must be used. The table can also make long cuts by chopping and then pushing the table towards the blade as shown in Fig. 10. Do not use table lock when cutting in this manner..

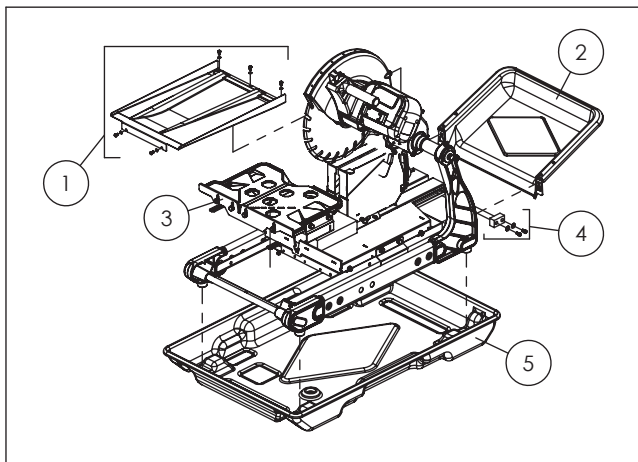

Figure 5: Prepping masonry saw to receive vacuum table

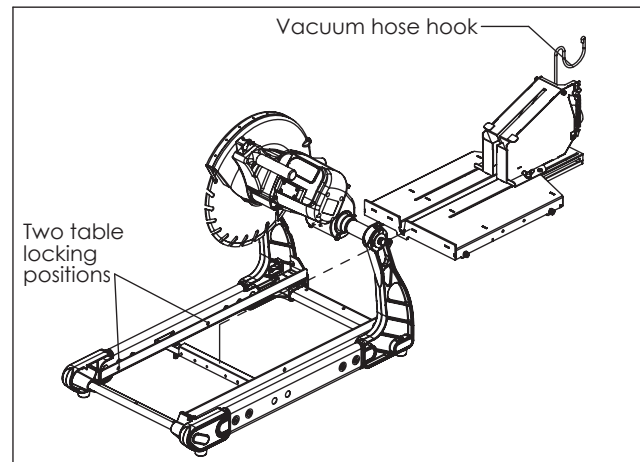

Figure 6: Underside view of the saw

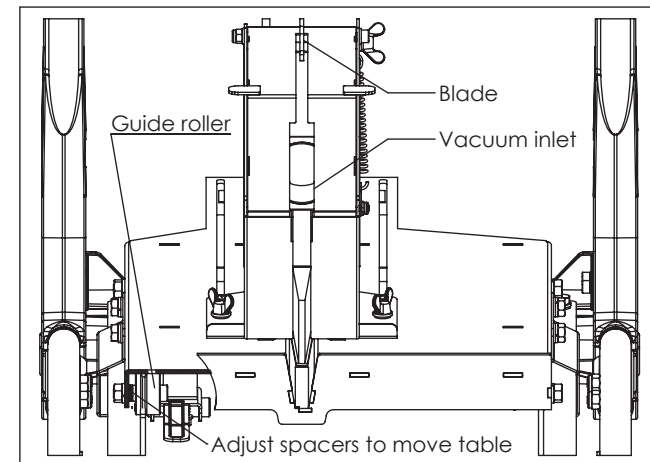

Figure 7: Using the vacuum table

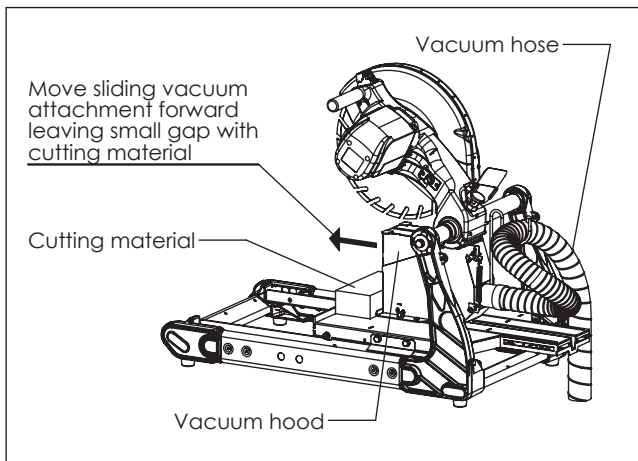

Figure 8: Using the vacuum table

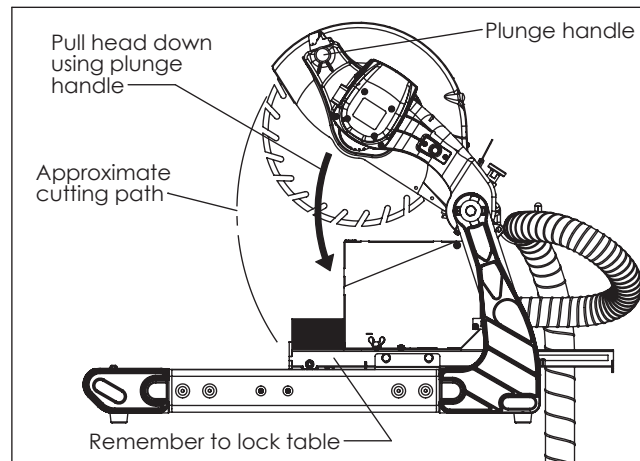

Figure 9: Chop cutting

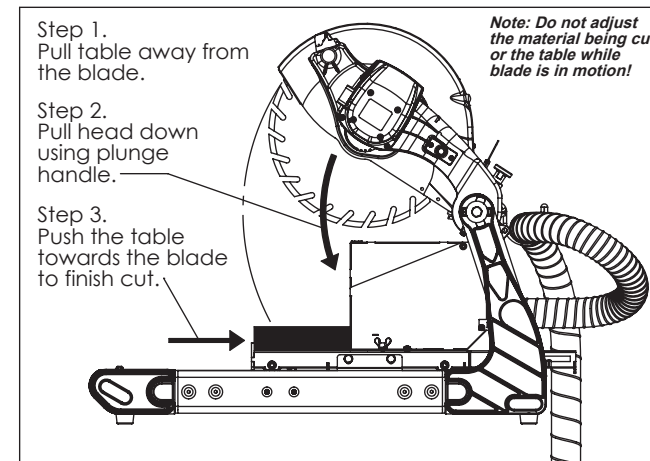

Figure 10: Long cutting