

PEARL®

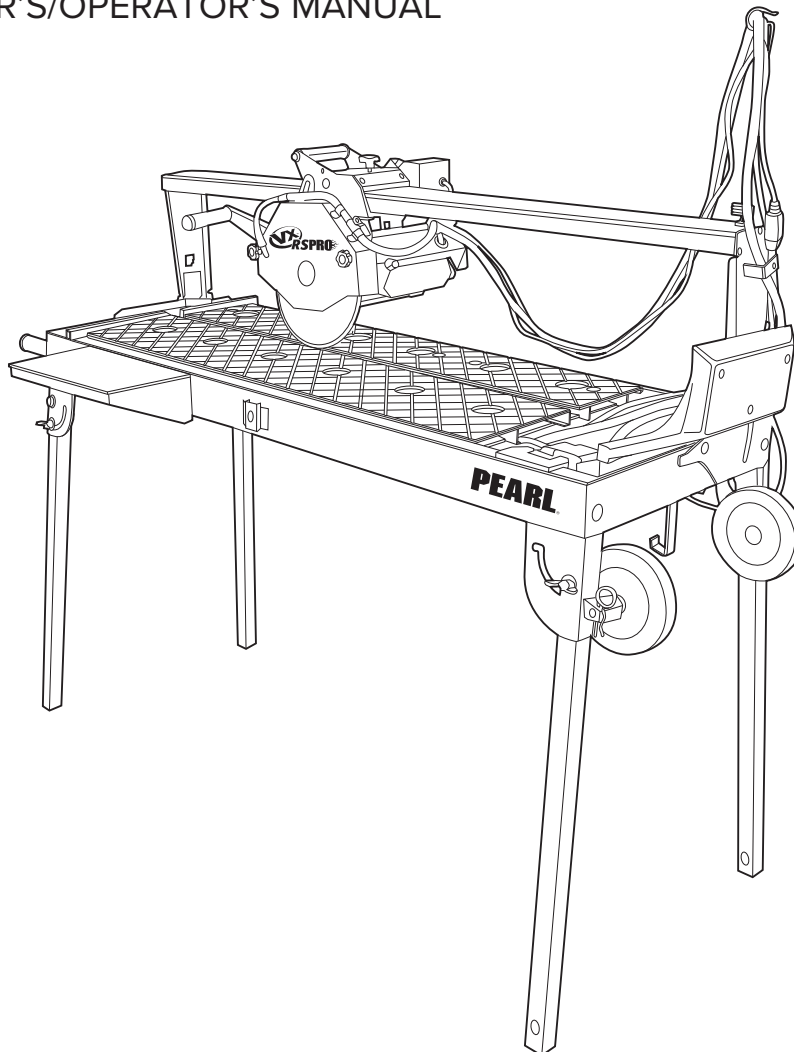

MODEL VX10RSPRO RAIL SAW OWNER'S/OPERATOR'S MANUAL



SERIAL NUMBER -

You should record the Serial Number of your saw on this Owner's/Operator's Manual and on the Warranty Card.

The Warranty Card must be sent back with all the required pertinent information for the warranty to take effect.

Caution! Read Safety and General Instructions carefully before using saw for the first time.

 **WARNING:** This product can potentially expose you to chemicals that are known to the State of California to cause cancer and birth defects or other reproductive harm. For more information, go to: www.P65Warnings.ca.gov

REV. 5

Patents Pending
Assembled in U.S.A.

RAIL SAW



PEARL ABRASIVE CO.

i. TABLE OF CONTENTS

	PAGE
ii. GENERAL SAFETY RULES AND PRECAUTIONS.....	3
iii. SILICA DUST WARNING	5
iv. FEATURES	5
v. SPECIFICATIONS	6
vi. UNPACKING, ASSEMBLY & SET-UP	6
vii. BLADE INSTALLATION	9
viii. MOTOR CAPACITOR INSTALLATION.....	9
ix. SIDE TABLE & SPLASH GUARD INSTALLATION.....	10
x. WATER PUMP INSTALLATION	10
xi. OVERFLOW PLUG INSTALLATION	10
xii. THE ADJUSTABLE ANGLE GUIDE	10
xiii. OPERATING THE SAW	11
xiv. CHOOSING THE RIGHT BLADE	12
xv. ELECTRIC MOTOR SPECIFICATIONS	13
xvi. DO'S AND DONT'S FOR BLADES.....	13
xvii. CARE AND MAINTENANCE.....	14
xviii. WATER PUMP MAINTENANCE.....	15
xix. ALIGNMENT INSTRUCTIONS	16
xx. TROUBLESHOOTING	17
xxi. HOW TO ORDER PARTS	18
xxii. CUSTOMER SERVICE	18
xxiii. REPLACEMENT PARTS LIST	19

ii. GENERAL SAFETY RULES AND PRECAUTIONS



WARNING!

Read all instructions. As with all machinery there are certain hazards involved with operation and use of the machine. The following basic safety precautions should be followed at all times to reduce the risk of fire, electric shock and serious personal injury to you or others. Keep these important operating instructions with this product.



1. Know your power tool - read owner's/operator's manual carefully. Learn its applications and limitations as well as the specific potential hazards unique to this tool.



2. Keep guards in place - and in working order.



3. Ground all tools - if tools are equipped with three prong plug, it should be plugged into a three-hole electrical receptacle. If an adapter is used to accommodate a two-prong receptacle, the adapter lug must be attached to a known ground. Never remove the third prong.



4. Remove wrenches - Form a habit of checking to see that adjusting wrenches are removed from tool before turning it "on".



5. Keep work area clean. Cluttered areas and benches invite accidents.



6. Do not use in dangerous environment. Do not use power tools in damp or wet locations, or expose them to rain. Keep work area well lighted. Do not use tool in the presence of flammable liquids or gasses.



7. Keep children and visitors away. All children and visitors should be kept at a safe distance from work area.



8. Make workshop childproof with padlocks, master switches or by removing starter keys.



9. Do not force tool. It will do the job better and be safer at the rate for which it was designed.



10. Use right tool. Do not force tool or attachment to do a job for which it was not designed.



11. Wear proper apparel. Do not wear loose clothing, gloves, neckties, rings, bracelets or other jewelry that may get caught in moving parts. Non-slip footwear is recommended. Wear protective hair covering to contain long hair.



12. Always use safety glasses. Wear safety glasses (must comply with ANSI Z87.1) at all times. Everyday eyeglasses only have impact resistant lenses; they are not safety glasses. Use face or dust mask if cutting operation is dusty, and ear protectors (plugs or muffs) during extended periods of operation.



13. Do not overreach. Keep proper footing and balance at all times.



14. Maintain tools in top condition. Keep tools sharp and clean for best and safest performance. Follow instructions for lubricating and changing accessories. Inspect tool cords periodically and if damaged, have repaired by authorized service facility.



15. Disconnect tools. When not in use, before servicing, and when changing accessories, such as blades, bits, cutters.

16. Avoid accidental starting. Make sure switch is in "off" position before plugging in power cord.

17. Use recommended accessories only. Consult the owner's manual for recommended accessories. The use of improper accessories may cause risk of injury to persons.

18. Never stand on tool. Serious injury could occur if the tool is tipped or if the cutting tool is accidentally contacted.

19. Check Damaged Parts. Before further use of the tool, a guard or other part that is damaged should be carefully checked to ensure that it will operate properly and perform its intended function. Check for alignment of moving parts, binding of moving parts, breakage of parts, mounting, and any other conditions that may affect its operation. A guard or part that is damaged should be properly repaired or replaced.

20. Never leave tool running unattended. Turn power "off". Do not leave tool until it comes to a complete stop.

21. Extension cords. Make sure your extension cord is in good condition. When using an extension cord, be sure to use one heavy enough to carry the current your product will draw. An undersized cord will cause a drop in line voltage resulting in loss of power and overheating. If in doubt, use the next heavier gage. The smaller the gage numbers the heavier the cord.

22. Do not abuse cord. Never carry tool by cord or pull it to disconnect from receptacle, Keep cord from heat, oil, and sharp edges.

23. Guard against electric shock. Prevent body contact with grounded surfaces. For example, pipes, radiators, ranges and refrigerator enclosures.

24. Outdoor use extension cords. When tool is used outdoors, use only extension cords intended for use outdoors and so marked.

25. Stay alert. Watch what you are doing. Use common sense. Do not operate tool when you are tired.

26. Drugs, alcohol, medication. Do not operate tool while under the influence of drugs, alcohol or any medication.

27. Store idle tool. When not in use, tool should be stored in a dry and locked place, out of reach of children.



WARNING!

CALIFORNIA PROPOSITION 65: Sawing and drilling generates dust. Excessive airborne particles may cause irritation to eyes, skin and respiratory tract. To avoid breathing impairment always employ dust controls and protection suitable to the material being saw or drilled in accordance with OSHA (29 CFR Part 1910.1). Diamond blades improperly used are dangerous. Comply with ANSI Safety Code B7.1 and OSHA covering speed, safety guards, flanges, mounting procedures, general operating rules, handling, storage and general machine condition.



KEEP GUARD IN PLACE



DIAMOND BLADE

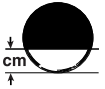

BLADE CUTTING DEPTH



ELECTRIC SWITCH OFF



ELECTRIC SWITCH ON



ELECTRICAL HAZARD



REMOVE TOOLS



PAY EXTREME ATTENTION



REPAIRS TO BE DONE



MACHINE HAZARD



FLAMMABLE



READ INSTRUCTIONS CAREFULLY



WARNING



FRAGILE



KEEP DRY



DO NOT STEP ON



WEAR HEARING PROTECTION



WEAR EYE PROTECTION



WEAR BREATHING PROTECTION



WEAR HARD HAT



WEAR PROTECTIVE CLOTHING



WEAR SAFETY SHOES

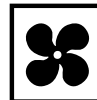

WELL VENTILATED



NO NON-WORKING PERSONNEL

iii. SILICA DUST WARNING



Grinding/cutting/drilling of tile, masonry, concrete, metal and other materials with silica in their composition may give off dust or mists containing crystalline silica. Silica is a basic component of sand, quartz, brick clay, granite and numerous other minerals and rocks. Repeated and/or substantial inhalation of airborne crystalline silica can cause serious or fatal respiratory diseases, including silicosis. In addition, California and some other authorities have listed respirable crystalline silica as a substance known to cause cancer. When cutting such materials, always follow respiratory precautions.

Use appropriate NIOSH-approved respiratory protection where dust hazard may occur. Paper masks or surgical masks without NIOSH approval number are not recommended because they do little to protect the worker. For more information about respirator programs, including what respirators have received NIOSH approval as safe and effective, please visit the NIOSH website at <http://www.cdc.gov/niosh/topics/respirators>

Observe OSHA regulations for respirator use (29 C.F.R. §1910.134).

Visit <http://www.osha.gov> for more information.

iv. FEATURES

The Pearl VX10RSPRO is a professional saw for cutting tiles, paving stones, large-sized natural stones, and similar materials.

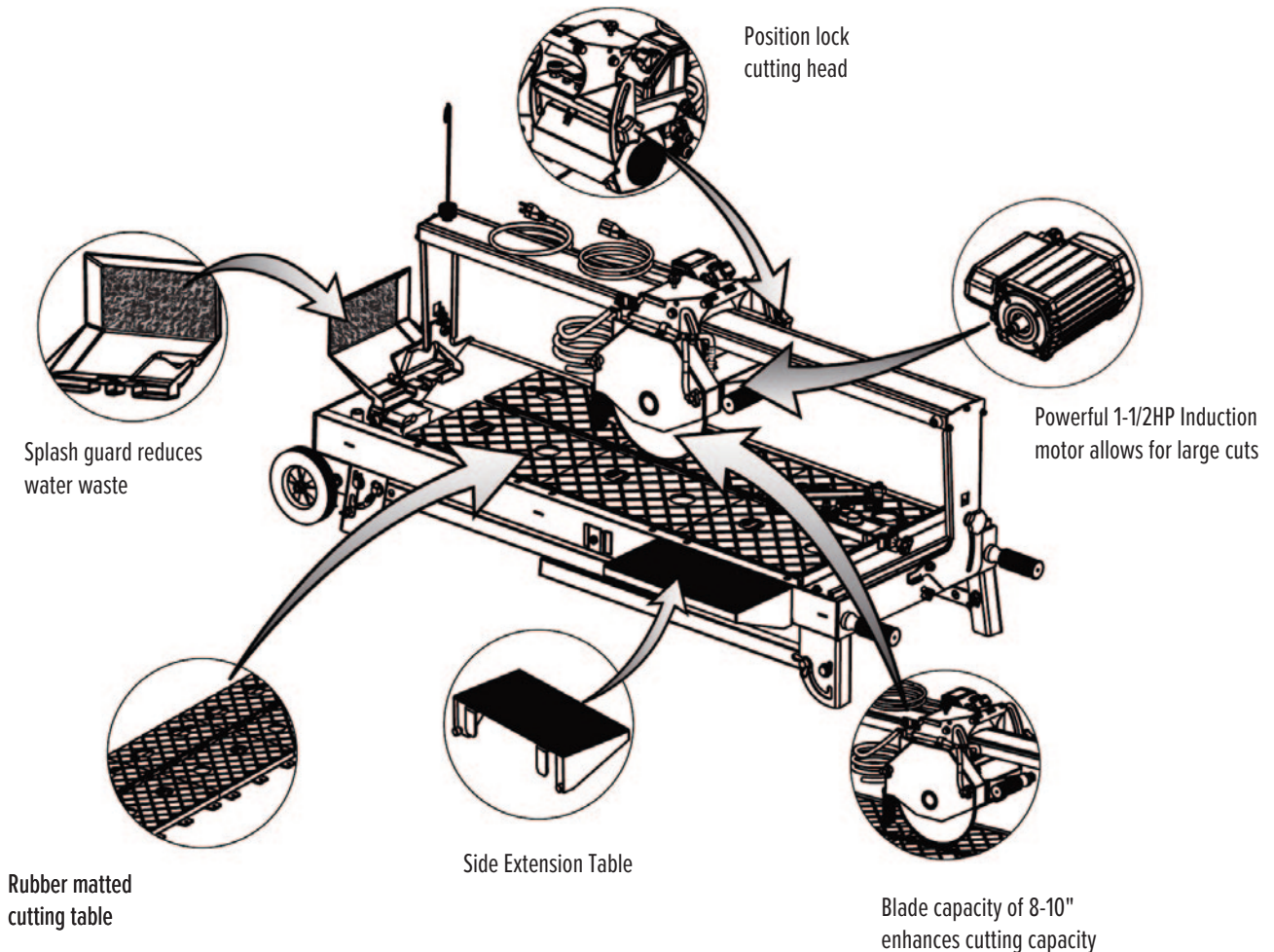

v. SPECIFICATIONS

VX10RSPRO RAIL SAW					
MOTOR	BLADE CAPACITY	CUTTING LENGTH	CUTTING DEPTH	WEIGHT	DIMENSIONS* (legs folded)
1-1/2 HP 115 v, 60 Hz, 3,450 rpm Induction motor	8"-10" Blade 5/8" arbor blade	46" rip cut, 32" diagonal with plunge cut	8": 1-1/2" 10": 2-5/8"	172 lbs.	L: 60" W: 25" H: 24"

*Dimensions do not include extension tables and drip trays.

vi. UNPACKING, ASSEMBLY & SET-UP

UNPACKING

Open the carton box cover by lifting the top portion. Locate the accessory box and check its content for the following items before discarding any packaging:

- Saw
- Universal Wrench
- Wheel Assemblies (2)
- Drain Plug
- Wing Screw
- Knobs (2)
- Angle guide
- Pin (2)
- Water Pump
- Owner's Manual
- Rear Splash Guard
- Extension Table
- Lifting handles (2)

Proceed to the following section to complete assembly of the saw.

ASSEMBLY & SET-UP

1. Remove the carton box cover by lifting the upper cover.
2. Locate the accessory box and open it. Obtain the two lifting handles and install one on each end of the saw. Install it in the side furthest from the post.
3. Loosen the lock knob on top of the cutting head.
4. Deploy the stand legs by following the “folded leg assembly” section.
5. Install the side extension table, side splash guard and back splash guard.
6. Install the spring holder on top of the sliding rail to hold the power cable and the water hose.
7. Fill the tray with water before operating the saw.

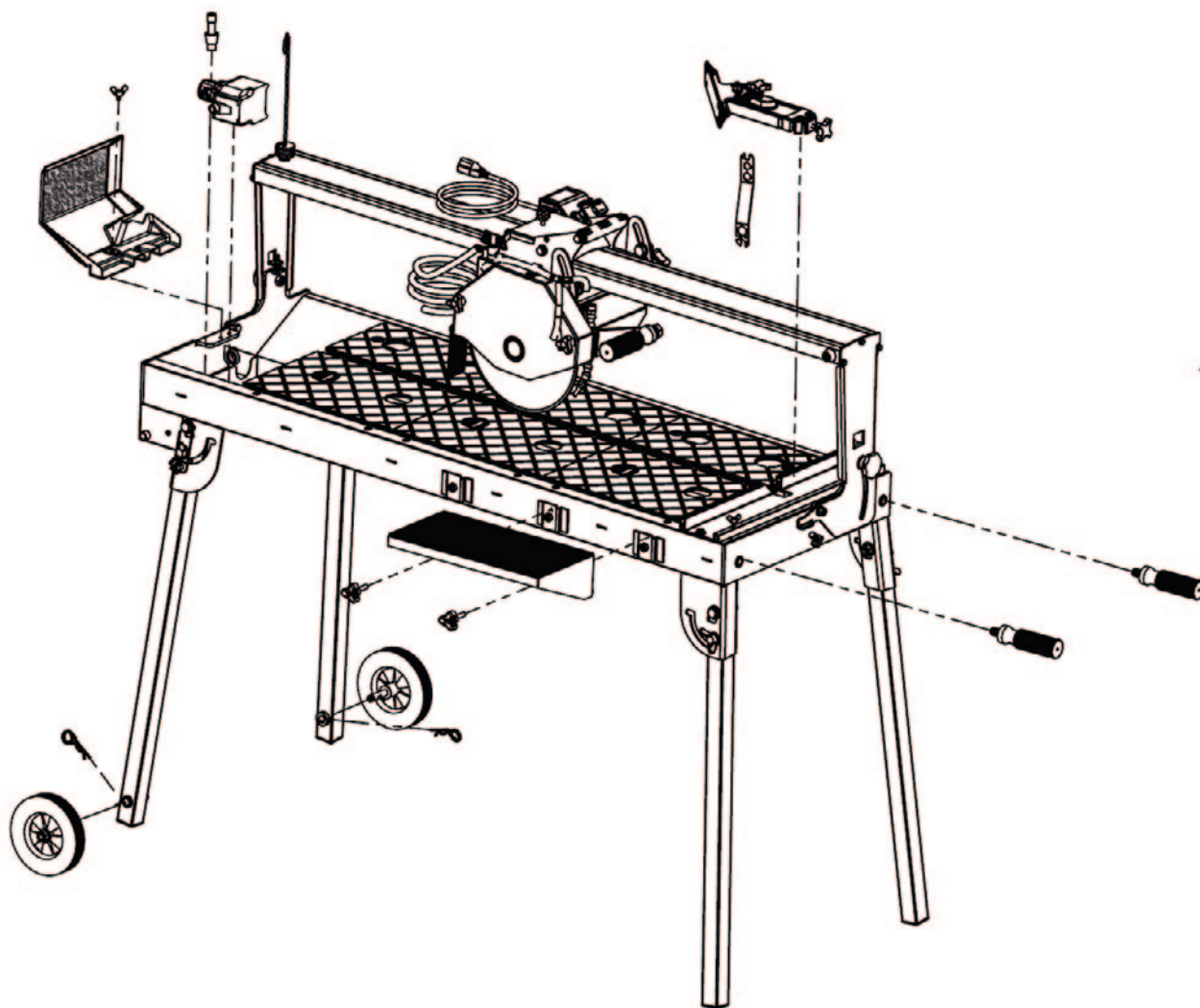

SAW STAND ASSEMBLY

FOLDING STAND

1. It is recommended that adjusting the folding leg be done by at least two people.
2. Remove the detachable wheel assembly and stow it on the frame.
3. Shift the cutting head away from the end of the frame where the leg is being adjusted. Tighten the cutting head carriage knob to hold the head in place.
4. Loosen the knob that is locking the leg in place.
5. Lift the saw slightly to give the leg room to rotate into stow/deployed position.
6. Slide the leg in place and tighten the knob.
7. Repeat steps 2-4 as required to the remaining legs.

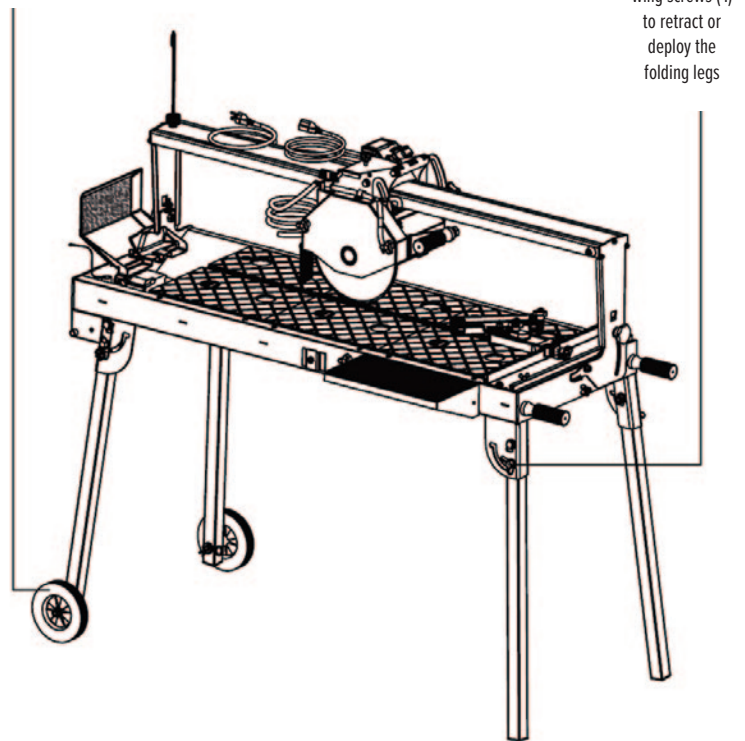
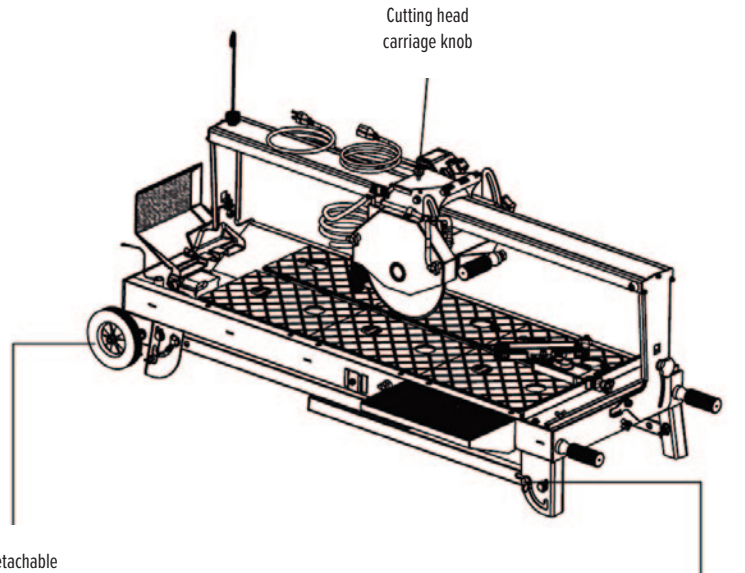

EASY TRANSPORT

1. It is recommended that adjusting the folding leg be done by at least two people.
2. Remove the detachable wheel assembly and stow it on the frame.
3. Shift the cutting head away from the end of the frame where the leg is being adjusted. Tighten the cutting head carriage knob to hold the head in place.
4. Loosen the knob that is locking the leg in place.
5. Lift the saw slightly to give the leg room to rotate into stow/ deployed position.
6. Slide the leg in place and tighten the knob.
7. Insert the detachable wheel assembly in either the frame/leg position depending on need.
8. Make sure the head is on the side closest to the wheels before transporting the saw.

vii. BLADE INSTALLATION

⚠ WARNING! *Disconnect the power plug before installing the blade onto the blade shaft.*

⚠ WARNING! *Setting the blade too low may damage the cutting table and if set too high, the blade may grab the material being cut, causing damage and possibly injury.*

Knurled Nuts

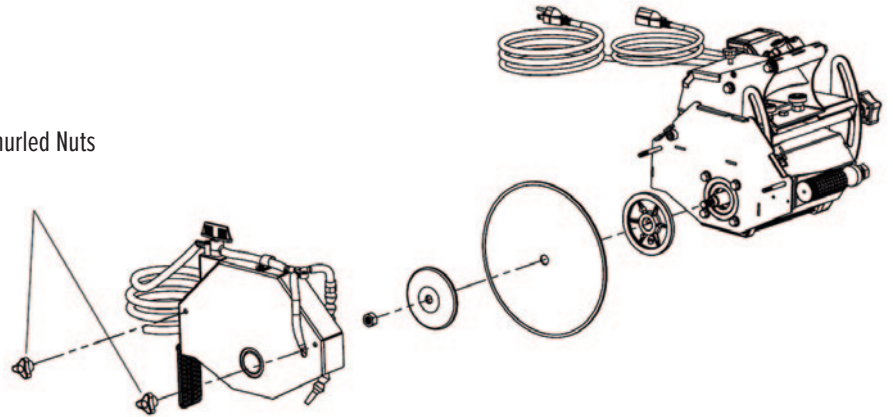

1. Loosen the knobs securing the blade guard and remove the guard.
2. Loosen the cutting shaft nut (left-hand thread); while loosening the nut, block the cutting shaft from turning.
3. Remove the blade clamping flange. Check that the contact area between the blade holder assembly and the diamond saw blade is clean.
4. Install the saw blade on the supporting flange. Ensure the blade rotation arrow matches the clockwise rotation of the saw blade shaft.
5. Install the blade clamping flange.
6. Re-tighten the cutting shaft nut. Block the cutting shaft from turning while tightening the nut.
7. Lightly turn the installed saw blade by hand and check the blade for true running.
8. Mount the blade guard.

viii. MOTOR CAPACITOR INSTALLATION

1. Locate the aluminum housing on the side of the motor body.
2. Using a phillip/cross screw driver to remove the two screws to open the capacitor housing cover.
3. Pull the capacitor out and remove the two wire caps to disconnect the wires.
4. Replace the old capacitor with the new capacitor and reattach the wires using the same wire caps.
5. Close the capacitor cover and make sure the rubber gasket is properly in place so no water can seep into the housing.

⚠ WARNING! *Disconnect the power plug before servicing the motor.*

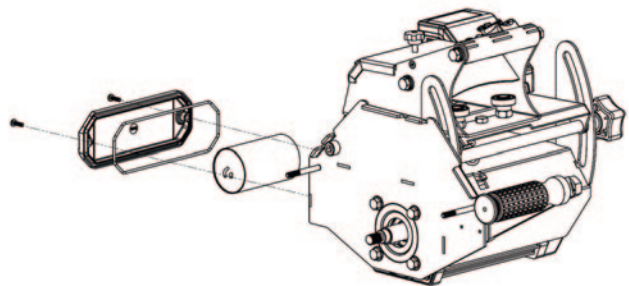

ix. SIDE TABLE & SPLASH GUARD INSTALLATION

Install the side table and splash guard as shown in the illustration to the side. Fasten the knobs/screws respectively to the saw frame.

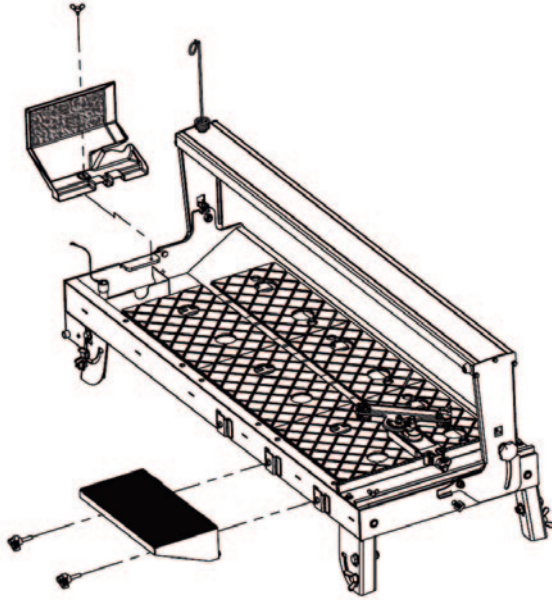

x. WATER PUMP INSTALLATION

1. Place the water pump into the bracket at the left front corner of the water tray, as shown on right.
2. Position the water outlet of the pump so that it lays horizontally. Connect the water hose from the blade guard to the water pump.
3. Plug the power cord into the 3-prong receptacle coming from the power switch housing.

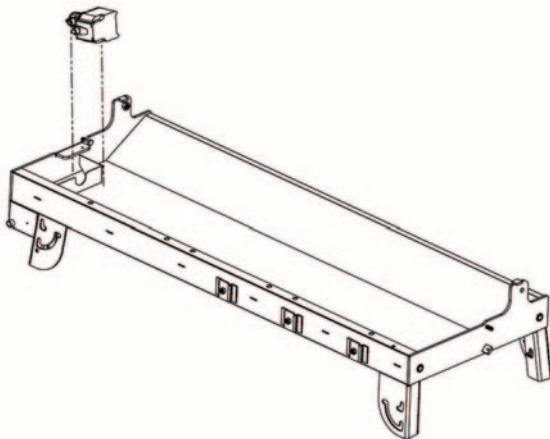

xi. OVERFLOW PLUG INSTALLATION

A tube at the rear end of the saw filters the debris from the water produced during the cutting operation. Debris settles in the water tray while the water is allowed to pass through the tube and into the water bucket, where fresh and filtered water reside.

1. Remove the water level tube from the plastic bag.
2. Insert the thin end of the tube into the rear hole next to the water pump, as shown in the illustration.
3. Fill the water tray with water.

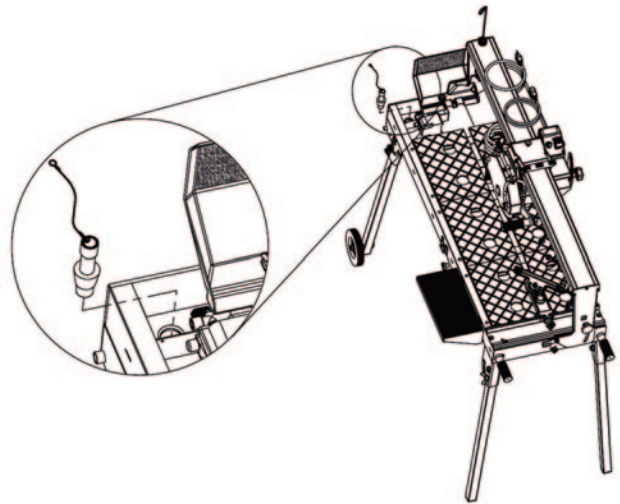

⚠ WARNING! Disconnect the pump before attempting to handle the pump. Never operate pump without water in the tray.

xii. THE ADJUSTABLE ANGLE GUIDE

The Adjustable Angle Guide is a two-piece assembly consisting of a base and an attachment that rotates. This guide will support cutting angles between 0°, 22.5°, 30°, 45° and many more. The attachment has a casted angle indicator that show what angle the Angle Guide is currently set to support.

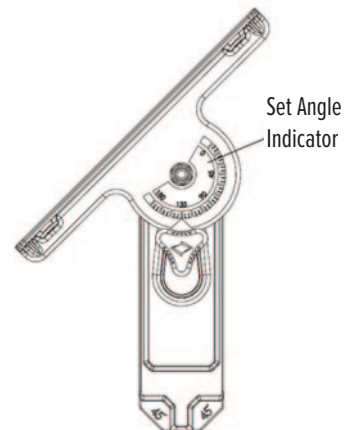

xiii. OPERATING THE SAW



1. After you have made yourself familiar with the components of your saw, the machine has been properly set up, the water tray is filled with water, and the electrical connection is established in accordance with the relevant safety regulations, you may now begin with the cutting operation.
2. Before you start operation open the water shut-off valve.
3. During the operation, the user must stand in front side of the saw pulling on one of the two handles of the cutting head when cutting. The workpiece must rest on the work table and should be pressed tightly against the cutting fence on the table.
4. Always turn off the saw before you leave the machine unattended.
5. Prevent accidental restarting of the saw by unplugging the power cable.

CUTTING AT CONSTANT DEPTH

When cutting at constant depth the cutting head must be pulled against the work piece. The motor should be turned off when adjusting the cutting depth.

1. Before starting the cut, hold the current depth by firmly grasping the plunge handle extending from the blade guard. Set the cutting head at the desired cutting depth by first loosening the depth control knob on the side of the cutting head where the switch box is located.
2. Adjust the head to the blade depth/clearance desired. Tighten the depth control knob.
3. Put the workpiece securely on the cutting table. Have it positioned to achieve the desired cut.
4. Turn on the saw and slowly and uniformly pull the head along the guide rail and across the workpiece.
5. Slowly return the cutting head to the original starting position and turn off the motor.

PLUNGE CUTS

The handling of long or partial cuts can be made using the plunge cutting method. In this case, the cutting head will not be set to a fixed cutting depth/clearance while performing a cut. The cutting head is freely movable during seesaw cutting operations.

1. Before starting the cut, the cutting head must be fully raised. Be sure to grasp the plunge handle extending from the blade guard. Loosen the depth control knob on the side of the cutting head where the switch box is located.
2. Set the workpiece securely on the cutting table. Have it positioned to achieve the desired cut.
3. With the head fully raised, move to the desired start of cut along the path of the blade. Plunge the head and pull until the desired cut is complete.
4. Slowly return the cutting head to the original starting position and turn off the motor.

THE CUTTING TABLE

FEATURES:

- The easily removable cutting table is covered with an anti-skid rubber coating, which allows the material being cut to sit on the table while the cutting head is pulled through it.
- Simply line up the material being cut with the appropriate pre-marked lines on the cutting table.

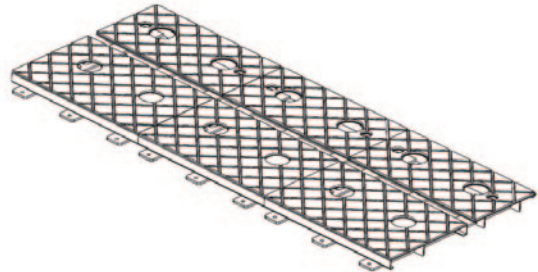

STEPS TO MAKE MITER CUTS:

1. The bench saw is equipped with a hinged guide rail that allows the user to make accurate miter cuts.
2. To pivot the guide rail, lightly loosen the knobs at both ends of the saw.
3. Set the rail to the desired angle by using both hands to firmly hold the rail and rotating it. While still holding the rail at the desired angle, tighten each knob.

 **WARNING!** Turn off the saw before pivoting the guide rail. Do not attempt to pivot the rail mid-cut. The saw blade must be clear of the material being cut and the saw must be turned off first!

CUTTING DEPTH

The recommended cutting depth is 1/4" below the cutting table surface. The cutting clearance has been fixed from original design.

BLADE DIAMETER	CUTTING DEPTH
8 inch	1-1/2 inch
10 inch	2-5/8 inch

WARNING! Setting the blade too low may damage the cutting table and if set too high, the blade may grab the material being cut, causing damage and possibly injury.

xiv. CHOOSING THE RIGHT BLADE

- The blade shaft speed of this saw is exclusively designed for cutting with diamond saw blades. The saw may only be used for cutting natural and artificial stone materials, do not cut wood or metal!
- The saw uses diamond saw blades with diameters up to 10". Saw blades with larger diameters must not be installed on the saw.
- Choose the correct type of saw blade for the material to be cut and the required cutting depth.

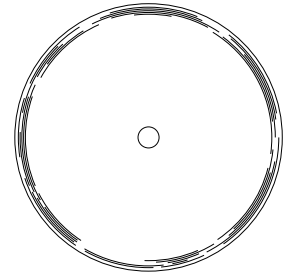

THE RIGHT BLADE DOES THE RIGHT JOB

For the most effective cutting and blade life always use the recommended Pearl Abrasive Co. blade.

PEARL BLADE SERIES	APPLICATION							
	CERAMIC TILE	EXTRA HARD CERAMIC	PORCELAIN	MARBLE	GRANITE	HARDSTONE	GLASS TILE	MOSAIC METAL TILES
Reactor ADM	○	○	○	○	○	○		○
HPXL Series	○	○	○	○	○	○		
HP Series		○	○		○			
Turbo Mesh		○	○		○	○		
DTLB19 Series	○							
Pro-V Series	○	○	○					
Glass Blade							○	
SH Series	○			○				

xv. ELECTRICAL MOTOR SPECIFICATIONS

Horse Power	1-1/2 hp
Volts	115 V/ 60hz
Amps	15 amps
Motor RPM	3,450 rpm
Cycle	60
Phase	1

⚠ WARNING: To avoid permanent motor damage you must use the correct extension cord. Never use more than one extension cord at a time. Follow the chart for proper size.

WIRE GAUGE	LENGTH OF CORD
No. 12	25'
No. 10	50'
No. 8	75'

Recommendations:

- It is recommended that a 20 amp circuit be used while operating this saw. This will prevent possible power interruption or loss.
- Always plug saw as close as possible to the power source while operating. This will allow you to receive optimum electricity.

Electrical Wiring Diagram

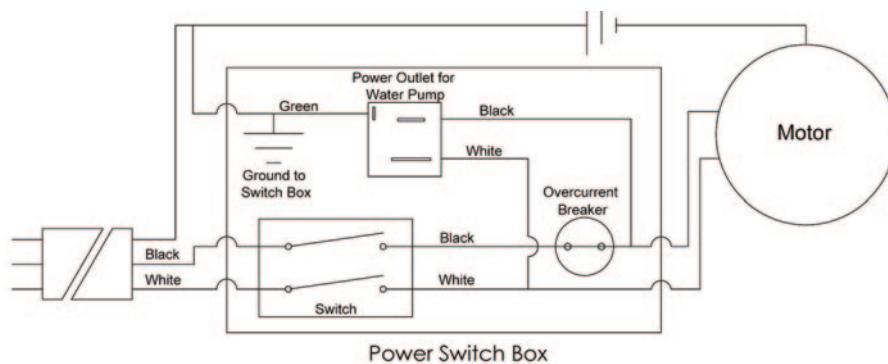

xvi. DO'S AND DONT'S FOR BLADES

WET CUT BLADES

DO'S

- Inspect blades daily for cracks or uneven wear.
- Always use appropriate blade for material being cut.
- Inspect arbor shaft for uneven wear before mounting blade.
- Always use blades with the correct arbor shaft size.
- Ensure that blade is mounted in the correct direction.
- Secure the blade to the arbor with a wrench.
- Use proper safety equipment when operating the saw.
- Periodically check the blade for cracks or bond fatigue.
- Always have a continuous flow of water on both sides of blade.

DONT'S

- Do not operate the saw without safety guards in position.
- Do not operate the saw with blades larger than 10".
- Do not cut dry with blades marked "Use Wet".
- Do not exceed manufacturer's recommended maximum RPM.
- Do not force blade into material let blade cut at its own speed.

DRY CUT BLADES

DO'S

- In addition to the following, always follow wet recommendations.
- Use appropriate blade for material being cut.
- Inspect segment blades for segment cracking or loss.
- Do not use damaged blades.
- Use proper safety equipment when operating the saw.

DONT'S

- In addition to the following, always follow wet recommendations.
- Do not make long cuts with dry blades--allow them to air cool.
- Do not use the edge or side of blade to cut or grind.
- Do not attempt to cut a radius or curve.
- Do not cut too deep or too fast into the material.
- Do not cut any material not recommended by blade manufacturer.

xvii. CARE AND MAINTENANCE



WARNING! For your safety before performing any maintenance on the saw, turn off the power switch and unplug the power cord.

GENERAL RULES

- Always clean the machine before maintenance/ repair.
- Before cleaning/maintenance/repair, the machine must be switched off with the main power key.

STEPS TO FOLLOW WHEN CLEANING

1. Please do not use aggressive cleaners (i.e. containing solvents). Do not use high-pressure water jets, aggressive detergents or solutions and liquids with a temperature exceeding 86°F Use a fluff-free cloth only.
2. Use a cloth which may be lightly moistened only for removing dust and dirt. Hard packed dirt can be removed with a soft brush.
3. For the sake of safety, no water/cleaning liquid/vapor may penetrate into the electric motor, connectors /plugs, switches, etc. Therefore cover all apertures, holes in the housing, connectors or plugs, etc. or seal them with adhesive tape.
4. Use a soft, low-pressure water jet and a brush to rinse dirt and incrustations away. Be particularly careful when near hazardous parts of the machine (e.g. switch, motor). Clean the motor and switches only by wiping with a moist cloth.
5. Do not "rinse" the bearings of the drive elements to prevent them from running dry. The ball bearings of the machine are permanently lubricated.
6. After cleaning, remove all covers and adhesive tape All screws/nuts which you may have loosened must be tightened again.
7. After wet cleaning, plug the machine to a power outlet which is equipped with a ground fault current interrupt. If the device cuts power, the machine must be inspected by an authorized dealer prior to use!

AFTER EVERY USE OF THE SAW:

- Remove dirty water from container.
- Remove dirt and mud from the bottom of the container.
- Rinse the immersion pump with fresh water to prevent water pump clogging from residual dirt.

AFTER WET CLEANING AND BEFORE USING THE SAW AGAIN:

- Connect the machine to an electric power outlet equipped with a "GFCI" safety power breaker. If the safety power breaker cuts off the electrical power supply, do not try to operate the machine but have it checked by an authorized dealer first.

BEFORE & AFTER A PROLONGED TIME

BEFORE NOT USING THE MACHINE FOR A PROLONGED PERIOD OF TIME:

- Clean and lubricate all movable parts. **DO NOT GREASE THE GUIDE RAILS.**

AFTER NOT USING THE MACHINE FOR A PROLONGED PERIOD OF TIME:

- Check that the legs are safely fixed.
- Check that all screw joints and nuts are fixed.
- Check that the roller table is rolling on the rails and that it moves securely back and forth. With the saw blade removed, switch on the motor for an instant and switch it off again. If the motor does not run, have the machine inspected by a qualified electrician.
- Check that the immersion pump works properly. Turn on the valve if applicable and switch the machine on. If the pump does not give any water or only a little, switch the machine

TEMPERATURE CHANGES

AMBIENT TEMPERATURE BELOW 37 F (WINTER)

To prevent the water in the pump and cooling system from freezing, remove the water after using the machine or when there will be a long break. Make sure that the cooling system is entirely drained so that there is no water left inside the pump, the bearing house and the water hose.

xviii. WATER PUMP MAINTENANCE



WARNING! For your safety before performing any maintenance on the saw, turn off the power switch and unplug the power cord.

When the machine has not been used for a long period of time, hard packed dirt may begin to build up inside the pump and block the pump wheel. If the machine is activated with the immersion pump blocked, the electric motor of the pump will be damaged within a few minutes. Please follow the steps listed below to clean the pump before operating the saw.

1. Unscrew the pump filter.
2. Remove the water pump from the water tray/ container.
3. Clean the water pump exterior.
4. Clean the interior where the fan is by removing the fan cover. If gasket is installed, be careful not to damage it.
5. The fan can be removed by using pliers to pull it off. Careful not to damage the fan or the motor shaft. With it removed, the entire volute can be cleaned easily.
6. Spin the pump shaft by hand. It should rotate almost effortlessly. Then press the cleaned fan back onto the blade. Note to align the shaft geometry with that of the blade bore before pressing it back on. Do not press the fan too far down the shaft or it may not rotate. Spin the fan blade by hand to confirm it can spin effortlessly.
7. Reassemble the fan cover.
8. Plug the water pump in briefly to check whether it works properly.

xx. ALIGNMENT INSTRUCTIONS



WARNING! For your safety before performing any maintenance on the saw, turn off the power switch and unplug the power cord.

REMINDER:

There are 3 methods to adjust the alignment:

1. Cutting fence.
2. Bridge.
3. Cutting head

Note: Usually adjustment method 1 and 2 are the most common.

METHOD 1: CUTTING FENCE

1. Loosen the bolts that secure the cutting fence.
2. Using a steel square, as shown in Fig. 1, align the square's long arm with the blade. Both the front and the rear end of the blade's rim should have contact.
3. Adjust the cutting fence such that the fence face sits flush with the steel square's short arm.
4. Now move the cutting head back and forth, along the bridge, to check for consistent blade contact with the steel square. Make sure the short arm does not move during this process. Interference from the blade may move the steel square away from the cutting fence.

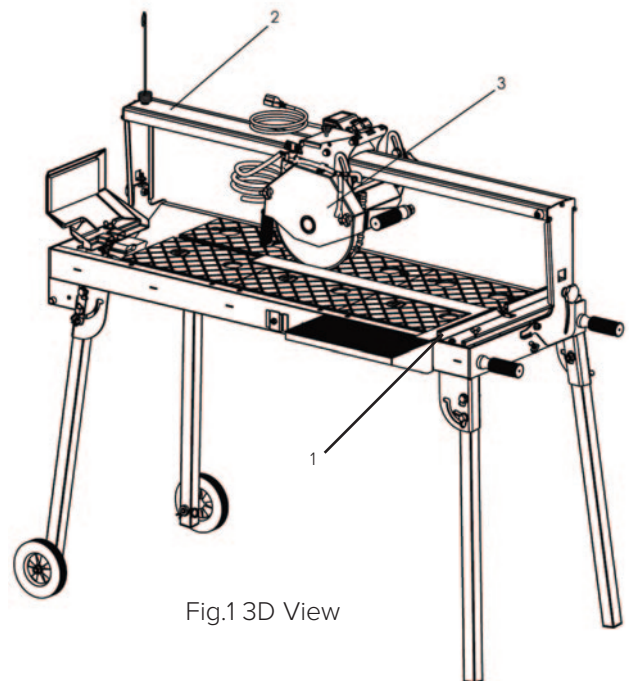

Fig.1 3D View

xix. ALIGNMENT INSTRUCTIONS (cont.)

METHOD 2: BRIDGE

1. Loosen the bolts that secure the bridge (Fig. 2). **DO NOT REMOVE THE BOLTS AS THE BRIDGE AND CUTTING HEAD WILL FALL.**
2. Repeat steps listed in method 1 to align the fence.
3. Now if the cutting fence does not move enough to align the cutting head, the bridge may be shifted as shown in the illustration below.

Adjustment range of the bridge/rail

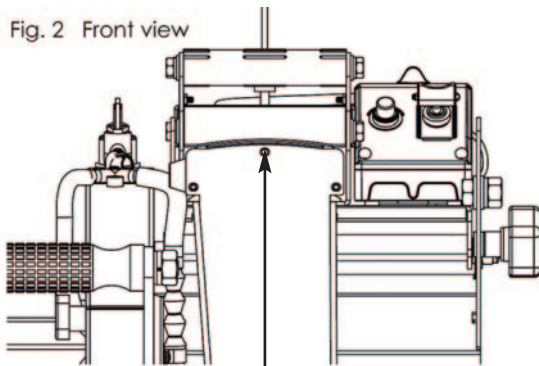

The post holes allow movement of the bridge +/- 0.5mm in either the left or right direction.

METHOD 3: CUTTING HEAD

1. Underneath the carriage cover is four bolts (size 13 wrench) that hold the head's two sub-assembly together. The upper assembly is the carriage and the lower assembly is the actual cutting head. The three bolts highlighted by the balloon "C", in the illustration below are the actual bolts

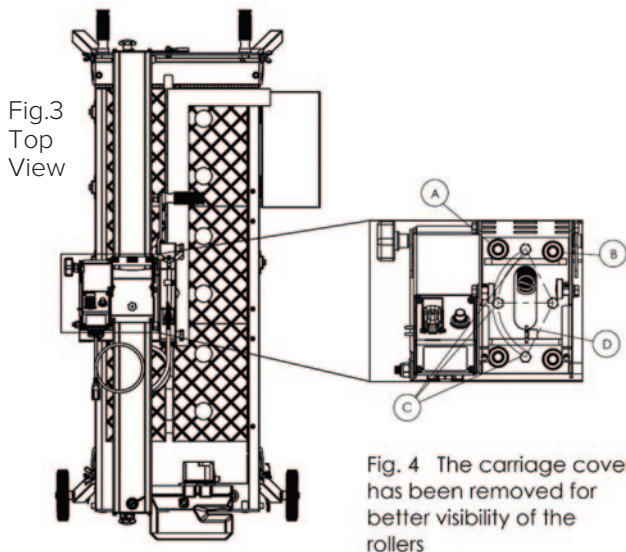

Fig. 4 The carriage cover has been removed for better visibility of the rollers

that need to be loosened. Only loosen the bolts enough that the lower sub-assembly can move, changing the blade shaft's orientation. The fourth bolt is the pivoting bolt and does not have to be loosened.

2. If the blade is constantly shifting left, using Fig. 4 as reference, the cutting head must be rotated counterclockwise (left).
3. If the blade is constantly shifting right, using Fig. 4 as reference, the cutting head must be rotated clockwise (right). Note: The cutting head should glide effortlessly across the bridge. Should the head be too tight or too loose, adjust the rollers on the left (A) using a size 17 wrench to rotate it. Rollers on the right (B) are fixed so they cannot be adjusted.

Fig. 5 depicts how aligning the blade with the steel square does not always mean the head is aligned with the bridge.



1. The solid line represents the steel square.
2. The dotted line represents the bridge and ACTUAL travel direction of the cutting head.
3. The rectangular box represents the blade/cutting head orientation. As the user pushes/pulls the cutting head if the cutting head is not properly aligned with the bridge, the blade will always moves away from the steel square.

xx. TROUBLESHOOTING

PROBLEM	POSSIBLE CAUSE	SOLUTION
MACHINE DOES NOT RUN WHEN SWITCHED ON	- Power cord not properly fixed/plugged in.	- Check that the machine is properly connected to the power supply.
	- Power cord defective.	- Have the power cord checked, replace if necessary.
	- Main power switch defective.	- Have the main power switch checked and replace if necessary by a qualified electrician.
	- Loose electrical connection inside the electric system.	- Have the whole electric system of the machine checked by a qualified electrician.
	- Motor defective.	- Have the motor checked and replaced if necessary by a qualified technician.
MOTOR STOPS (POWER CUT OUT)	- Too much pressure exerted while cutting.	- Exert less pressure when cutting.
	- Incorrect specification for saw blade.	- Use a saw blade which corresponds to the material being cut.
	- Saw has a defective electric system.	- Have the electric system of the saw checked by a qualified technician.
POOR MACHINE PERFORMANCE LITTLE POWER	- Power cord/extension cable too long or cable still wound up inside cable drum.	- Use a power cord/extension cable of the rated length, use a cable drum with cable fully extended.
	- Power network is insufficient.	- Observe the electrical ratings of the machine and connect it only to a power network which complies with these ratings.
	- Drive motor no longer runs at rated speed (r.p.m.).	- Have the motor checked by a qualified electrician and have it replaced if necessary.
INSUFFICIENT FLOW OF COOLING WATER OR NO COOLING WATER AT ALL	- The pump draws air.	- Fill the container with water.
	- Filter clogged.	- Clean the filter of the pump.
	- Pump wheel of the immersion pump blocked by dirt.	- Disassemble the immersion pump and clean.
IRREGULAR RUN OF THE SAW BLADE	- Poor tension in the blade material.	- Return the saw blade to the manufacturer.
SAW BLADE WOBBLER WHEN RUNNING	- Saw blade is damaged or bent.	- Have the saw blade aligned/ flattened. - Clean the receiving flange. - Solder the diamond segments of the old blade onto another saw blade or use a new blade.
	- Flange of the saw blade is damaged. Shaft of the motor bent.	- Replace the saw blade flange. - Replace the electric motor.
DIAMOND SEGMENT BECOMES LOOSE	- Overheating of the saw blade; cooling water not sufficient.	- Have the diamond segment soldered on the blade again; ensure optimum flow of cooling water.

PROBLEM	POSSIBLE CAUSE	SOLUTION
EXCESSIVE WEAR	<ul style="list-style-type: none"> - Wrong type of saw blade. - Shaft of motor causes wobbling. - Overheating. 	<ul style="list-style-type: none"> - Use harder saw blades. - Have bearings of the motor or the motor replaced. - Ensure optimum flow of cooling water. - Use appropriate type of saw blade.
SAW BLADE IS BLUNT	- Saw blade type is unsuitable for the material being cut.	
	- Saw blade type is unsuitable for the machine performance.	
	- Saw blade too hard.	
APPEARANCE OF CUT IS NOT OPTIMAL	- Diamond segments are blunt.	- Sharpen the diamond saw blade.
	- Poor tension in the blade material.	- Return the saw blade to the manufacturer.
	- Too much load placed on the saw blade.	- Use a suitable saw blade.
THE CENTER HOLE IN THE SAW BLADE HAS BECOME WIDER DUE TO WEAR	- Diamond segments are blunt.	- Sharpen the saw blade.
	- The saw blade has slipped on the motor shaft when running.	- The arbor of the saw blade must be fitted with an appropriate adaptor ring.
		- Check the receiving flange and have it replaced if necessary.
SAW BLADE SHOWS BLOOMING COLORS	- Ensure an optimum flow of cooling water.	
	- The material feed is too high; proceed more slowly.	
GRINDING MARKS ON THE SAW BLADE	- Saw blade overheating due to a lack of cooling water.	- The material feed is too high; proceed more slowly.
	- Lateral friction when cutting.	- Ensure that the direction of feed is absolutely parallel to the saw blade.
	- Material is not being fed parallel to the saw blade	- Adjust the roller table or have it adjusted.
	- Poor tension in the blade material.	- Have the saw blade tensioned.
	- Too much load on the saw blade.	- The material feed is too high, proceed more slowly.

xxii. HOW TO ORDER PARTS

Please have the following information ready before calling: Model Number of the Tile Saw and Part Description

For warranty purpose, please have the following ready: Serial Number and When purchased and where

All parts listed may be ordered from your Local warehouses. If the part is not stocked locally, call our Corporate office and ask for our Customer Service Department. For Technical Support call 1-800-969-5561. In Canada, call 1-800-387-0008. There is a \$25.00 minimum order.

Return Policy: Return goods for credit or exchange on the basis of the following terms: (1) They must be current products; (2) Items returned for replacement or refund should be in original cartons and must be accompanied by a packing slip with the following information: Returned Goods Authorization (RGA) number obtainable from Customer Service Department • List of items returned • Reason(s) for return(s) • Copy of original invoice(s); (3) Freight charges must be assumed by sender; (4) Returning goods are subject to a 15% handling charge to cover our cost of repacking and restocking. All Prices are subject to change without notice.

Disclaimer: Pearl Abrasive Co. reserves the right to make changes or improvements on its products without incurring an additional obligation including any obligation to make corresponding changes or improvements to products previously manufactured or sold. Pearl reserves the right to discontinue products at any time without notice.

All illustrations displayed in this manual are the property of Pearl Abrasive Co. and shall not be duplicated or reproduced without the express written consent of Pearl Abrasive Co.

xxiii. CUSTOMER SERVICE

AFTER SALE SERVICE

All customer service (technical questions, re-order of parts, etc.) will be provided by our company. All spare parts for after sales service will be stocked and shipped from our warehouse. If requested, we may arrange for our sales representatives to hold a training class for product knowledge at dealer's location.

xxiii. REPLACEMENT PARTS LIST

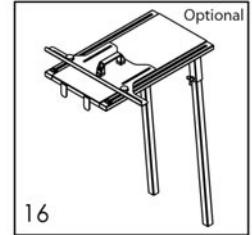
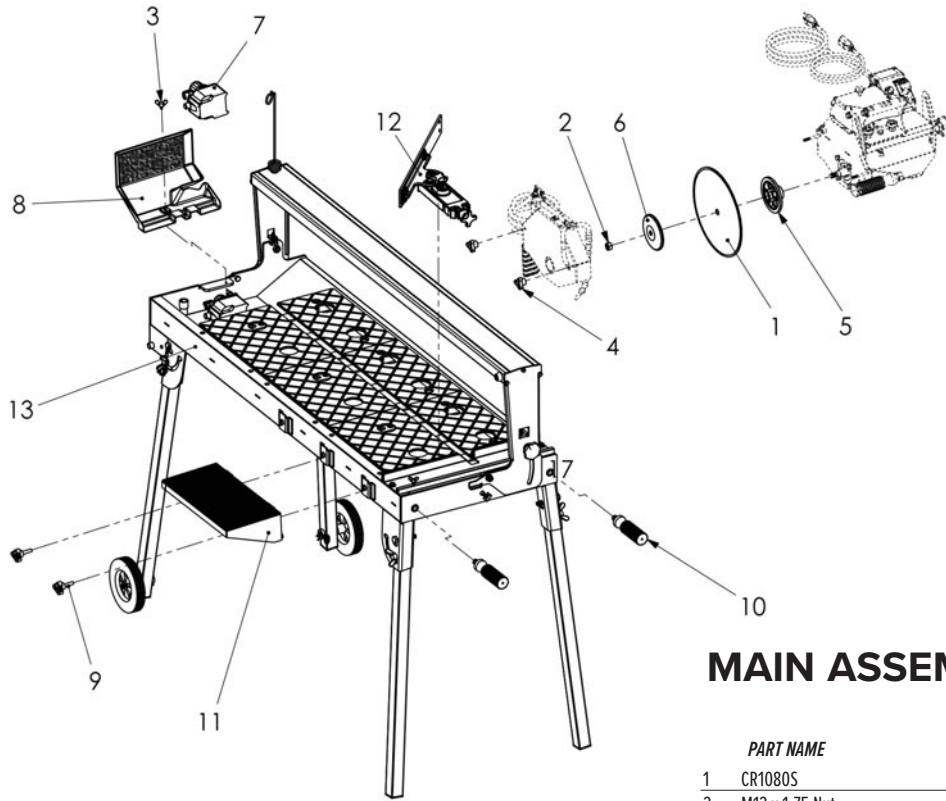

MAIN ASSEMBLY

PART NAME	PART NUMBER
1 CR1080S	PACR1080S
2 M12 x 1.75 Nut	PA102728
3 M6 x 1.0 x 10L Wing screw	PA4294
4 M6 x 1.0 Female knob	PA0610041
5 10" Inner flange	PA103832
6 10" Outer flange	PA103834
7 Water Pump	PSV00006
8 Splash guard	PA103905
9 M8 x 1.25 Male knob	PA103906
10 35D x 120L Handle with rubber	PA150313
11 Extension table - Black	PA103908
12 180 Degree adjustment angle guide	PA103909
13 Frame assembly w/4 of legs - Black	PA103910
16 Long side extension table w/rubber mat and 2 legs	PA103850

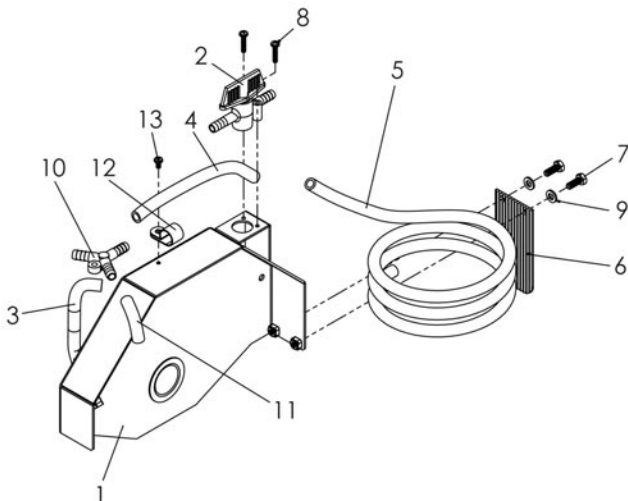

BLADE GUARD

PART NAME	PART NUMBER
1 Outer blade guard weldment - Black	PA103868
2 Plastic male 5/16" x male 5/16" barbed straight valve	PA00001JI
3 12D 8d X 120L Reinforced water hose	PA103870
4 12D 8d X 180L Reinforced water hose	PA103871
5 12D 8d X 2430L Reinforced water hose	PA103872
6 Splash guard	PA140275
7 M6 x 1.0 x 16L Cross hex bolt	PA140347
8 M4 x 0.7 x 20L Cross screw	PA420046
9 M6x13x1T Wide Washer	PA0384
10 Barbed wye tube fitting	PA102723
11 12D 8d X 90L Reinforced water hose	PA103873
12 12D Hose clamp	PA140315
13 M4 x 0.7 x 8L Cross screw	PA1374

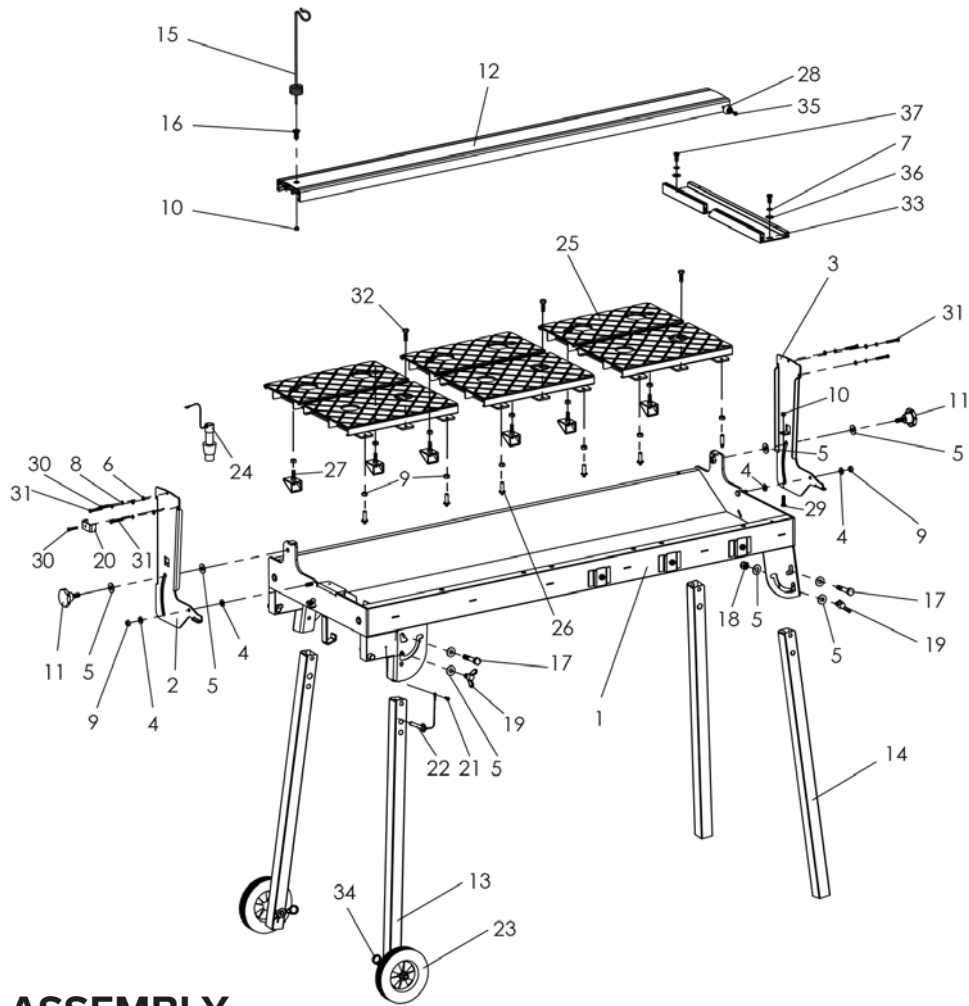

FRAME ASSEMBLY

PART NAME	PART NUMBER	PART NAME	PART NUMBER
1 Frame weldment - Black	PA103891	20 Cable clamp	PA102719
2 Post A - Black	PA103893	21 M4 x 0.7 x 10L Cross screw	PA0353
3 Post B - Black	PA103895	22 Safety pin with chain	PA42148
4 (5/16)M8 x 25 x 1.8 Washer (electroplated)	PA150119	23 6 inch Wheel assembly	PA140381
5 M10 (D41 d10.5 X 3L) Wide washer	PA0306	24 Overflow plug assembly	V102767
6 M5 x 10 x 1 Flat Washer	PA25054	25 Table assembly	PA103900
7 M6 Spring Lock Washer	PA11090	26 Table support screw	PA103901
8 M5 Spring Lock Washer	PA25053	27 Table support feet arrangement	PA103902
9 M 8 x 1.25 Nylon Nut	PA100086	28 20D x 10L M5 Rubber stop	PA102751
10 M6 x 1.0 Nut	PA150334	29 M6 x 1.0 x 25L Hex bolt	PA420319
11 Male seven lobe T1 knob M10 x 1.5 x 25L	PA102705	30 M5 x 0.8 x 25L Hex bolt	PA140282
12 Bridge/Rail	PA103897	31 M5 x 0.8 x 35L Hex bolt	PA160081
13 Rear leg weldment	PA103898	32 M8 x 1.25 x 25L Hex bolt	PA150145
14 Front leg weldment	PA103899	33 Ruler guide	PA103903
15 Cable suspension spring	PA103924	34 D4 X 45L Hairpin cotter pin (25D shaft)	PA140229
16 Spring rest	PA103810	35 M5 x 0.8 x 16L Cross screw	PA25058
17 M10 x 1.5 x 60L Cap hex bolt	PA4291	36 M6 x 18 x 1.8T Very Big Washer	PA103904
18 M10 x 1.5 Nylon Nut	PA140267	37 M6 x 1.0 x 16L Hex bolt	PA11089
19 M10 x 1.5 x 20L Wing screw	PA103820		

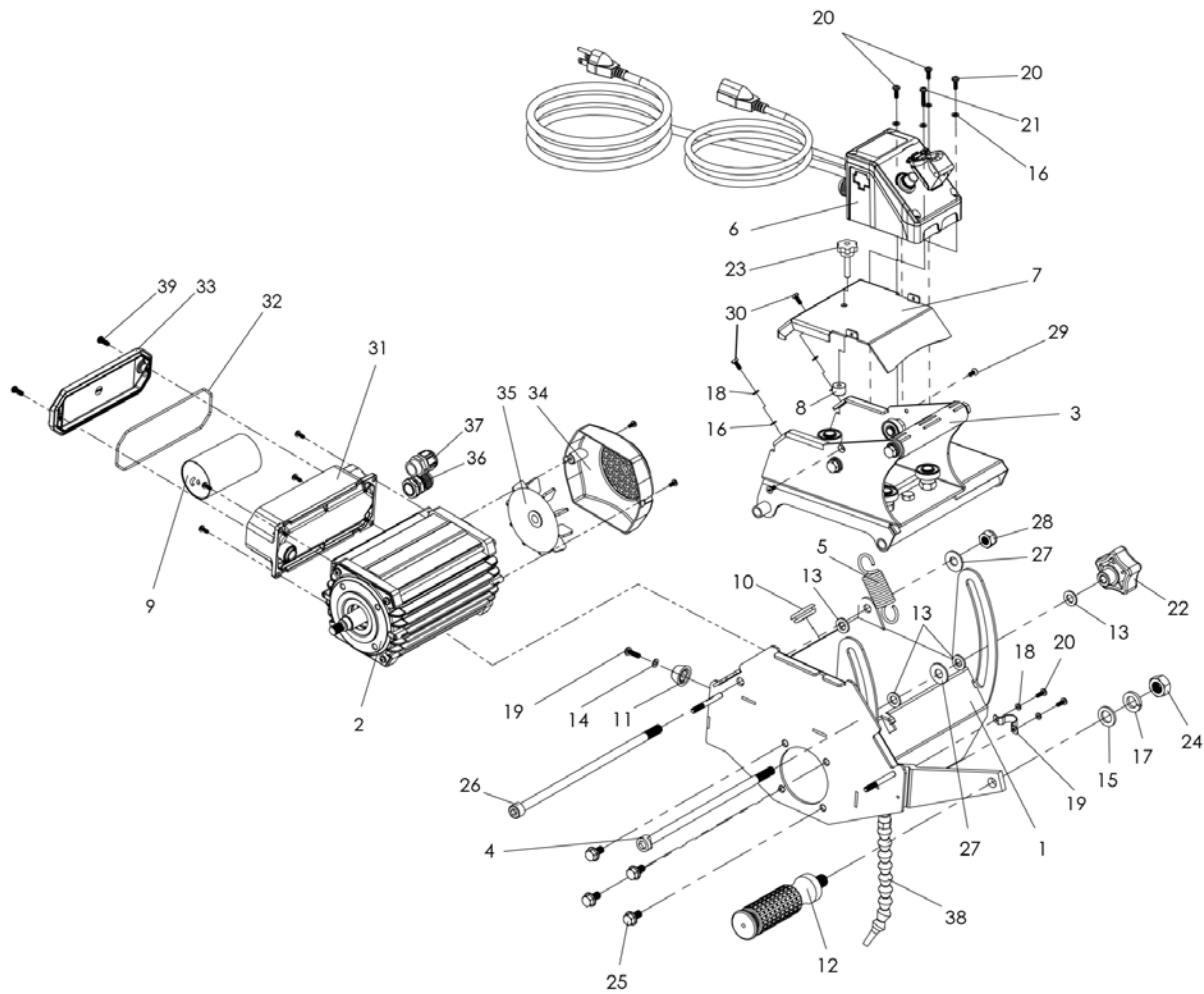

CUTTING HEAD ASSEMBLY

<i>PART NAME</i>	<i>PART NUMBER</i>
1 Cutting head weldment - Black	PA103874
2 1.5HP Electric motor - KWW105	PA103876
3 Rail carriage assembly - Black	PA103877
4 M10 x 1.5 x 230 Slot bolt	PA103879
5 Helical Spring	PA103921
6 Power switch housing complete	PA103922
7 Cutting head position bracket - Black	V370039
8 M6 x 1.0 Screw boot	PA103789
9 80uF/250VAC 50/60Hz Capaciter	PA103791
10 32D d17 Rubber grommet	PA140281
11 20D x 10L M5 Rubber stop	PA171056
12 35DX120L Handle with rubber sleeve	PA102736
13 (3/8)M10 x 25 x 2T Teflon washer	PA140344
14 M5 x 10 x 1T Narrow washer	PA25054
15 M14 x 26 x 2T Wide washer	PA140346
16 M4 x 8 x 1T Narrow washer	PA420044
17 M14 Spring Lock Washer	PA103883
18 M4 Spring Lock Washer	PA15999
19 13mm OD hose clip	PA103783
20 M4 x 0.7 x 12L Cross screw	PA141113

<i>PART NAME</i>	<i>PART NUMBER</i>
21 M4 x 0.7 x 25L Cross screw	PA103884
22 Female M10 X 1.5 Knob	PA102746
23 M6 x 1.0 x 30L Knob	PA102739
24 M14 x 2.0 Nut	PA140345
25 M8 x 1.25 x 16L Hex Flange bolt	PA103885
26 M10 x 1.5 x 260L x 2S Socket head cap hex screw	PA103923
27 M10 Wide washer	PA0306
28 M10 x 1.5 Nylon nut	PA140267
29 M4 x 0.7 x 10 Countersunk cross screw	PA25055
30 M4 x 0.7 x 10L Hex bolt	PA102549
31 Capacitor housing	PA103797
32 Gasket	PA103798
33 Capacitor housing cover	PA103792
34 Fan cover	PA103795
35 Fan	PA103796
36 PG-13.5 Cable gland	PA103794
37 PG-11 Cable gland	PA150224
38 M4 x 0.7 x 14L Cross screw	PA103793
39 M5 x 0.8 x 16L Cross screw	PA25058

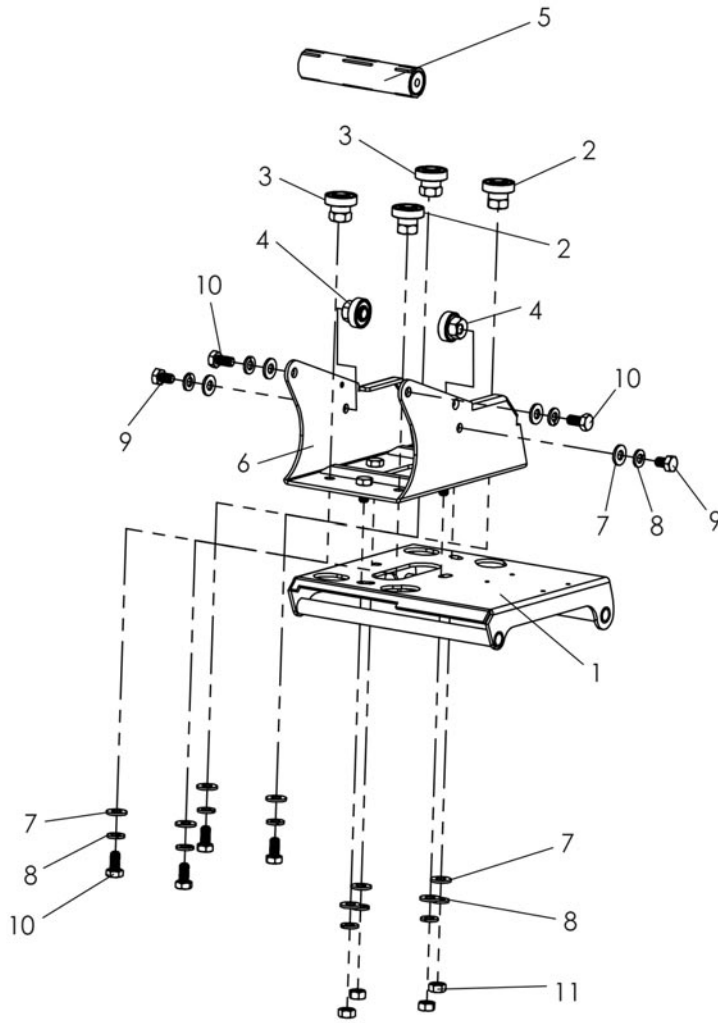

CUTTING HEAD SUB-ASSEMBLY

<i>PART NAME</i>	<i>PART NUMBER</i>
1 Carriage B weldment - Black	PA103886
2 Concentric flat roller	PA103800
3 Eccentric flat roller	PA103801
4 Eccentric flat roller	PA102745
5 Slide handle with rubber sleeve	PA102732
6 Carriage A weldment - Black	PA103803VX
7 M8 x 18 x 1.8T Wide washer	PA230166
8 M8 Spring lock washer	PA0121
9 M8 x 1.25 x 12L Hex bolt	PA100087
10 M8 x 1.25 x 16L Hex bolt	PA103799
11 M 8 x 1.25 Nut	PA0119

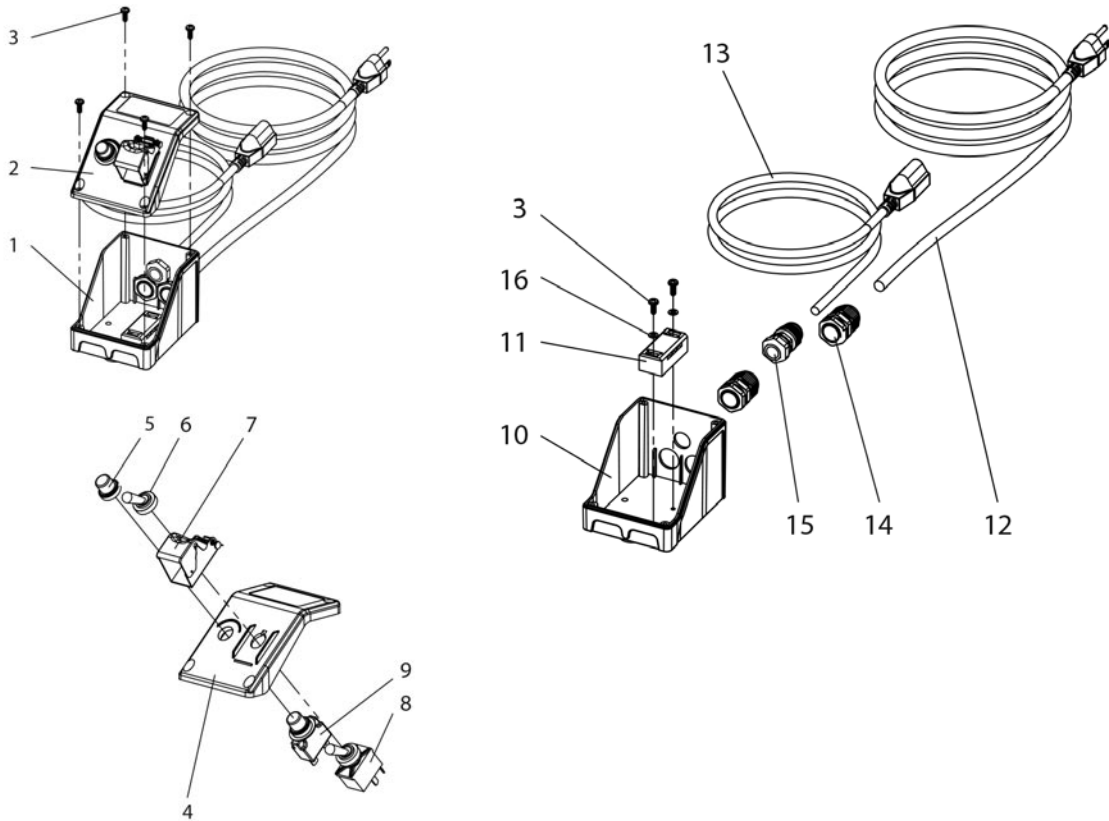

SWITCH BOX ASSEMBLY

<i>PART NAME</i>	<i>PART NUMBER</i>
1 Lower power switch assembly	PA103836
2 Upper power switch assembly	PA103837
3 M 4 X 1.59 X 12L Cross tapping screw	PA130038
4 Switch box upper housing	PA103838
5 Reset button boot	S1000-03.1
6 Toggle Switch Boot	S1000-03.2
7 Power switch shield / Toggle Switch Safety Bracket	PA100003
8 15A/125V Toggle switch with rubber boot	PSV00001
9 18A/125V Circuit breaker	PA141038
10 Switch box lower housing	PA103839
11 Junction box	PA420290
12 14AWGx3C X 3M NEMA 5-15P Power plug	PA102748
13 16AWGx3C X 2M NEMA 5-15R Power cable	PA102711
14 PG-11 Cable gland	PA150224
15 PG-9B Power cable gland	PA102744
16 M4 x 8 x 1T Teflon washer	PA150241

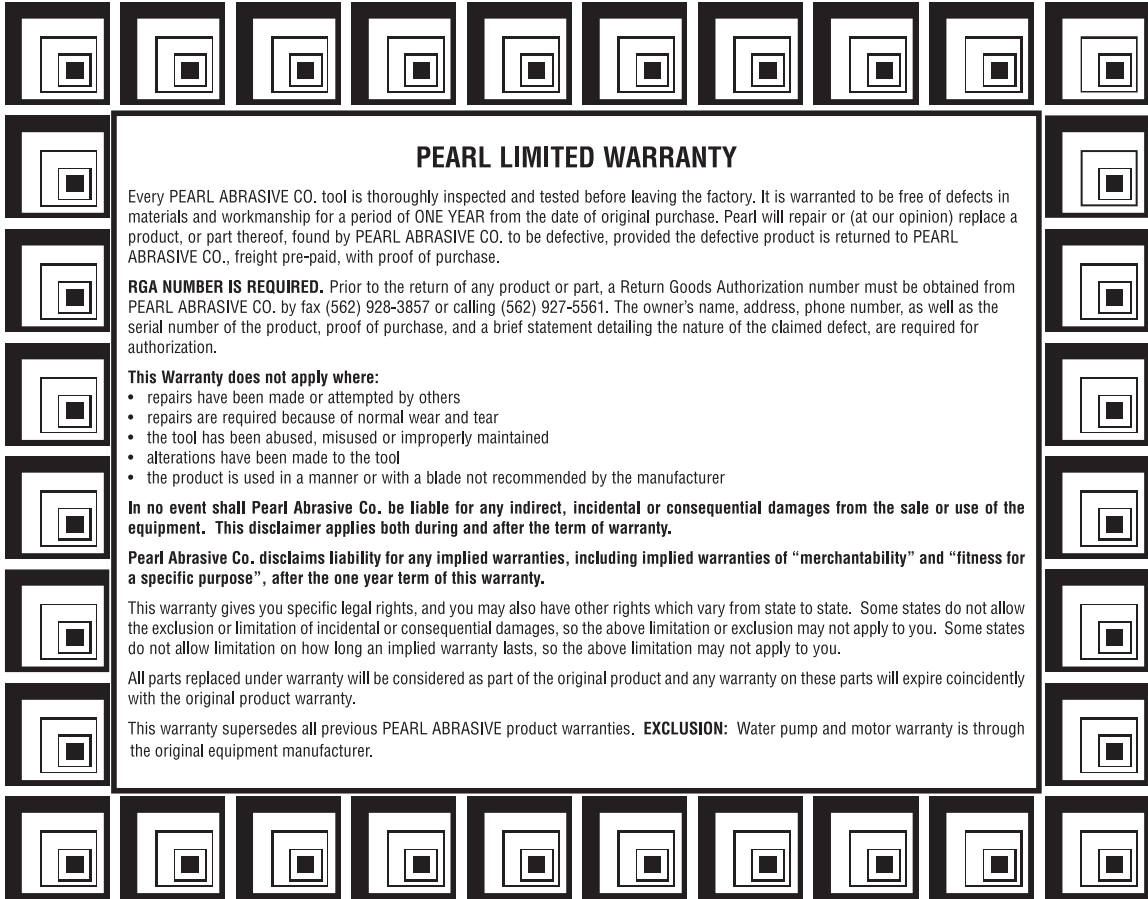

PEARL LIMITED WARRANTY

Every PEARL ABRASIVE CO. tool is thoroughly inspected and tested before leaving the factory. It is warranted to be free of defects in materials and workmanship for a period of ONE YEAR from the date of original purchase. Pearl will repair or (at our opinion) replace a product, or part thereof, found by PEARL ABRASIVE CO. to be defective, provided the defective product is returned to PEARL ABRASIVE CO., freight pre-paid, with proof of purchase.

RG# NUMBER IS REQUIRED. Prior to the return of any product or part, a Return Goods Authorization number must be obtained from PEARL ABRASIVE CO. by fax (562) 928-3857 or calling (562) 927-5561. The owner's name, address, phone number, as well as the serial number of the product, proof of purchase, and a brief statement detailing the nature of the claimed defect, are required for authorization.

This Warranty does not apply where:

- repairs have been made or attempted by others
- repairs are required because of normal wear and tear
- the tool has been abused, misused or improperly maintained
- alterations have been made to the tool
- the product is used in a manner or with a blade not recommended by the manufacturer

In no event shall Pearl Abrasive Co. be liable for any indirect, incidental or consequential damages from the sale or use of the equipment. This disclaimer applies both during and after the term of warranty.

Pearl Abrasive Co. disclaims liability for any implied warranties, including implied warranties of "merchantability" and "fitness for a specific purpose", after the one year term of this warranty.

This warranty gives you specific legal rights, and you may also have other rights which vary from state to state. Some states do not allow the exclusion or limitation of incidental or consequential damages, so the above limitation or exclusion may not apply to you. Some states do not allow limitation on how long an implied warranty lasts, so the above limitation may not apply to you.

All parts replaced under warranty will be considered as part of the original product and any warranty on these parts will expire coincidentally with the original product warranty.

This warranty supersedes all previous PEARL ABRASIVE product warranties. **EXCLUSION:** Water pump and motor warranty is through the original equipment manufacturer.

PEARL®

CORPORATE OFFICE: SO. CALIFORNIA • USA
4900 ZAMBRANO ST., COMMERCE, CA 90040
FAX 562-927-5561 / 562-928-3857
PHONE 800-969-5561
www.pearlabrasive.com

GEORGIA • USA
455 SATELLITE BOULEVARD
SUWANEE, GA 30024

ONTARIO • CANADA
375-2 PIDO ROAD
PETERBOROUGH, ONTARIO K9J-6X7