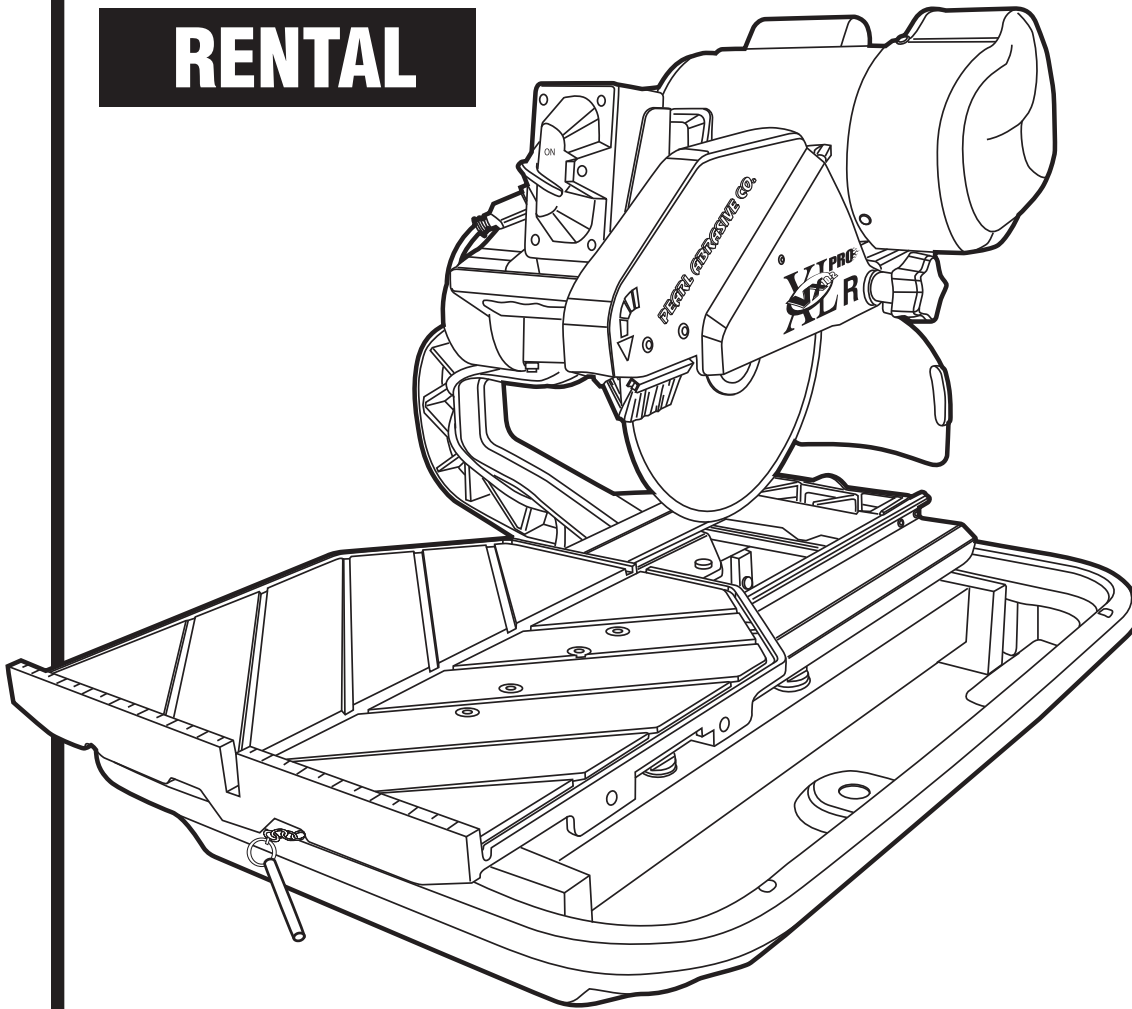


# PEARL®

# XLPROR

**MODEL VX10.2XLPROR TILE  
SAW OWNER'S/OPERATOR'S MANUAL**

**RENTAL**



**SERIAL NUMBER -**

You should record the Serial Number of your Tile Saw on this Owner's/Operator's Manual and on the Warranty Card. **The Warranty Card must be sent back with all the required pertinent information for the warranty to take effect.**

**Caution!** Read Safety and General Instructions carefully before using saw for the first time.

**!** **WARNING:** This product can potentially expose you to chemicals that are known to the State of California to cause cancer and birth defects or other reproductive harm. For more information, go to: [www.P65Warnings.ca.gov](http://www.P65Warnings.ca.gov)

**REV. 7**

Covered by one or more of the following  
US Patents: 6,080,041; 6,119,676;  
6,272,990; 6,460,533; and D458,282

**PEARL ABRASIVE CO. XL TILE SAW**

# TABLE OF CONTENTS

	PAGE
I. GENERAL SAFETY RULES FOR ALL POWER TOOLS.....	3
II. SYMBOLS .....	4
III. FEATURES .....	5
IV. SPECIFICATIONS .....	5
V. GETTING TO KNOW YOUR SAW.....	6
VI. BLADE INSTALLATION .....	7
VII. SAFE OPERATING PRACTICES FOR TILE SAW .....	7
VIII. GROUNDING INSTRUCTIONS.....	9
IX. USING THE CUTTING TABLE.....	10
X. CARE AND MAINTENANCE .....	11
XI. BEARING HOUSING REPLACEMENT .....	13
XII. CUTTING DEPTH .....	13
XIII. BELT REPLACEMENT .....	14
XIV. REPLACEMENT PART LISTS .....	14
XV. ACCESSORIES AND PARTS .....	19
XVI. THE RIGHT BLADES DOES THE RIGHT JOB .....	20
XVII. HOW TO ORDER PARTS .....	20
XVIII. ELECTRICAL MOTOR SPECIFICATION.....	21
XIX. TROUBLESHOOTING .....	22

## i. GENERAL SAFETY RULES FOR ALL POWER TOOLS



**WARNING!** Read all instructions. As with all machinery there are certain hazards involved with operation and use of the machine. The following basic safety precautions should be followed at all times to reduce the risk of fire, electric shock and serious personal injury to you or others. Keep these important operating instructions with this product.



1. Know your power tool - read owner's/operator's manual carefully. Learn its applications and limitations as well as the specific potential hazards unique to this tool.



2. Keep guards in place - and in working order.



3. Ground all tools - if tools are equipped with three prong plug, it should be plugged into a three-hole electrical receptacle. If an adapter is used to accommodate a two-prong receptacle, the adapter lug must be attached to a known ground. Never remove the third prong.



4. Remove wrenches - Form a habit of checking to see that adjusting wrenches are removed from tool before turning it "on".



5. Keep work area clean. Cluttered areas and benches invite accidents.

6. Do not use in dangerous environment. Do not use power tools in damp or wet locations, or expose them to rain. Keep work area well lighted. Do not use tool in the presence of flammable liquids or gasses.



7. Keep children and visitors away. All children and visitors should be kept at a safe distance from work area.

8. Make workshop childproof with padlocks, master switches or by removing starter keys.

9. Do not force tool. It will do the job better and be safer at the rate for which it was designed.

10. Use right tool. Do not force tool or attachment to do a job for which it was not designed.



11. Wear proper apparel. Do not wear loose clothing, gloves, neckties, rings, bracelets or other jewelry that may get caught in moving parts. Non-slip footwear is recommended. Wear protective hair covering to contain long hair.



12. **Always use safety glasses.** Wear safety glasses (must comply with ANSI Z87.1) at all times. Everyday eyeglasses only have impact resistant lenses; they are not safety glasses. Use face or dust mask if cutting operation is dusty, and ear protectors (plugs or muffs) during extended periods of operation.



13. Do not overreach. Keep proper footing and balance at all times.



14. Maintain tools in top condition. Keep tools sharp and clean for best and safest performance. Follow instructions for lubricating and changing accessories. Inspect tool cords periodically and if damaged, have repaired by authorized service facility.



15. Disconnect tools. When not in use, before servicing, and when changing accessories, such as blades, bits, cutters.



16. Avoid accidental starting. Make sure switch is in "off" position before plugging in power cord.

17. Use recommended accessories only. Consult the owner's manual for recommended accessories. The use of improper accessories may cause risk of injury to persons.



18. Never stand on tool. Serious **injury** could occur if the tool is tipped or if the cutting tool is accidentally contacted.



19. Check Damaged Parts. Before further use of the tool, a guard or other part that is damaged should be carefully checked to ensure that it will operate properly and perform its intended function. Check for alignment of moving parts, binding of moving parts, breakage of parts, mounting, and any other conditions that may affect its operation. A guard or part that is damaged should be properly repaired or replaced.

20. Never leave tool running unattended. Turn power "off". Do not leave tool until it comes to a complete stop.

21. Extension cords. Make sure your extension cord is in good condition. When using an extension cord, be sure to use one heavy enough to carry the current your product will draw. An undersized cord will cause a drop in line voltage resulting in loss of power and overheating. Extension cord tables (refer to page 21) show the correct size to use depending on cord length and nameplate ampere rating. If in doubt, use the next heavier gage. The smaller the gage numbers the heavier the cord.
22. Do not abuse cord. Never carry tool by cord or pull it to disconnect from receptacle, Keep cord from heat, oil, and sharp edges.
23. Guard against electric shock. Prevent body contact with grounded surfaces. For example, pipes, radiators, ranges and refrigerator enclosures.
24. Outdoor use extension cords. When tool is used outdoors, use only extension cords intended for use outdoors and so marked.
25. Stay alert. Watch what you are doing. Use common sense. Do not operate tool when you are tired.
26. Drugs, alcohol, medication. Do not operate tool while under the influence of drugs, alcohol or any medication.
27. Store idle tool. When not in use, tool should be stored in a dry and locked place, out of reach of children.



**WARNING! CALIFORNIA PROPOSITION 65:** Sawing and drilling generates dust. Excessive airborne particles may cause irritation to eyes, skin and respiratory tract. To avoid breathing impairment always employ dust controls and protection suitable to the material being saw or drilled in accordance with OSHA (29 CFR Part 1910.1). Diamond blades improperly used are dangerous. Comply with ANSI Safety Code B7.1 and OSHA covering speed, safety guards, flanges, mounting procedures, general operating rules, handling, storage and general machine condition.

## ii. SYMBOLS



KEEP GUARD IN PLACE



REPAIRS TO BE DONE



WEAR HEARING PROTECTION



DIAMOND BLADE



MACHINE HAZARD



WEAR EYE PROTECTION



BLADE CUTTING DEPTH



FLAMMABLE



WEAR BREATHING PROTECTION



ELECTRIC SWITCH OFF



READ INSTRUCTIONS CAREFULLY



WEAR HARD HAT



ELECTRIC SWITCH ON



WARNING



WEAR PROTECTIVE CLOTHING



ELECTRICAL HAZARD



FRAGILE



WEAR SAFETY SHOES



REMOVE TOOLS



KEEP DRY



WELL VENTILATED



PAY EXTREME ATTENTION



DO NOT STEP ON



NO NON-WORKING PERSONNEL

### iii. FEATURES

The Pearl VX10.2XLPROR is a portable professional tile saw. Lightweight and compact it has innovative built in features that enable it to cut larger format tiles. The unique main table allow the saw to increase its cutting capacity when needed. The main table and extension carriage are supported by low friction, self cleaning, adjustable guide wheels. Water flow to the blade is provided by two (2) nozzles that directs the water to both sides of the blade. The rugged powder coated steel frame sets in a removable water tray for easy clean up.

- **Powerful Motor - 2 hp.**
- **Heavy Duty ON/OFF switch.**
- **Automatic Thermal Overload protects your saw from power surges and motor overheating.**
- **Heavy Duty Stainless Steel Water Tray.**
- **Stainless Steel Rail guides.**
- **Adjustable Cutting Head allows user to align saw at any time.**
- **10-Sealed Metal Roller bearings.**
- **Blade Capacity - 10".**
- **Diagonal Cut up to 18" tiles and rip cut up to 24" in length.**

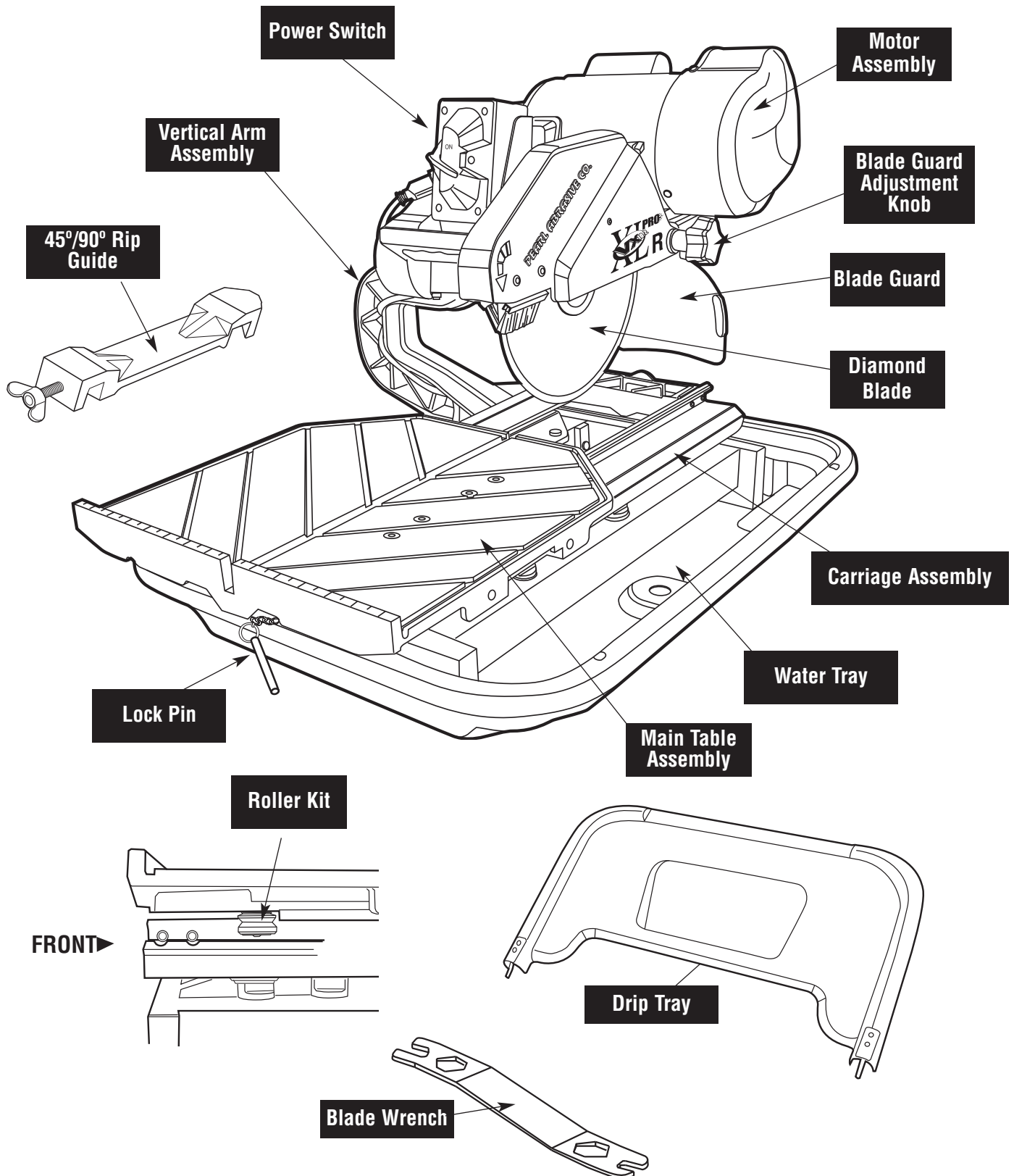
The heavy duty, cast to last, construction and quality components were designed to meet the highest demands of the professional.

**Read this manual completely** and then let the Pearl VX10.2XLPROR take your cutting capabilities to new dimensions.

### iv. SPECIFICATIONS

<b>VX10.2XLPROR TILE SAW</b>				
<b>MOTOR</b>	<b>ARBOR SHAFT ROTATION</b>	<b>MAX. BLADE CAPACITY</b>	<b>WEIGHT</b>	<b>DIMENSIONS</b>
2 HP 115 v, 60 Hz, Single phase	Counter- Clockwise	5/8" arbor blade, 8, 9 & 10" Blade	84 lbs.	Width: 21" Length: 24"

## V. GETTING TO KNOW YOUR SAW



## vi. BLADE INSTALLATION

1. Carefully raise the cutting head to its highest position and secure it into place by tightening the cutting head adjustment knob in the rear support.
2. Raise the blade guard to the highest position and tighten the blade guard adjustment knob.
3. Remove the blade shaft nut and outer flange.
4. Place the blade onto the shaft making sure that the directional arrows are pointing in the direction of rotation.
5. After making sure that the blade is firmly placed against the inner flange, secure it into place with the outer flange and blade shaft nut. Make certain the nut is firmly tightened with the wrench provided, but **do not over tighten!**
7. Lower the blade guard and tighten the adjustment knob.
8. Slightly loosen the rear support adjustment knob, lower the cutting head so that the blade is 3/16" to 1/4" below the surface of the cutting table, and then tighten the adjustment knob firmly to hold the cutting head in place.

**WARNING:** Setting the blade too low may damage the cutting table and if set too high, the blade may grab the material being cut, causing damage and possibly injury.

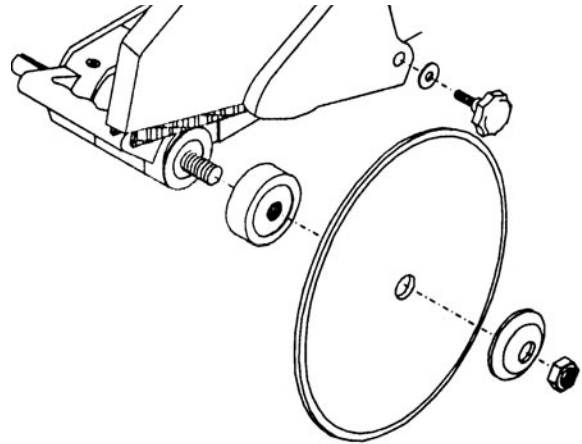


Figure 1

## vii. SAFE OPERATING PRACTICES FOR TILE SAW

**WARNING!** For your own safety and the safety of others do not attempt to operate this saw until you have read and understand the general safety rules for all power tools and the following additional safety precaution unique to this saw.

1. Use safety equipment - wear safety approved hearing, eye, head and respirator protection.

**WARNING!** The dust generated by cutting of tile, marble, stone, bricks etc. can be injurious to your health. Always operate machinery in well ventilated areas and provide proper dust removal. Always wear a dust mask approved for respiratory protection against these types of dusts and mists.

2. Read and understand the symbol definitions contained in this manual.



3. Read and understand all warnings and instructions on the machine.
4. Read all safety materials and instructions that accompany any blade or accessory used with this machine.
5. Establish a training program for all operations of this machine.
6. Always provide a copy of this manual to the equipment user. If you need extra copies call our Customer Service Department at **1-800-969-5561**.
7. Always select a diamond blade according to the manufacturers recommendation suitable for the material to be cut. Never use a blade having a maximum operating speed lower than the "No load R.P.M." marked on the tool





nameplate. Do not operate any saw without safety guards in place or with a blade diameter larger than the maximum saw blade capacity.

8. Before mounting a blade on the saw clean and inspect the arbor shaft, blade flanges and the diamond blade for uneven wear or damage. If it appears to be damaged, **Do not operate the tool.** Have it serviced by a qualified service technician.



9. Before each use of the saw, inspect the diamond blade for hairline fatigue cracks. If such a crack or flaw is evident, discard the blade. **Using a damaged blade may cause injury to the operator or others.**

10. Be sure that the blade arbor hole matches the blade adapter flange supplied with the saw. Use only blade adapter flanges that came on your saw. Never use damaged or worn blade adapter flanges.



11. **Installing the blade,** install the blade with the arrow pointing the same direction as the rotation of the arbor shaft or the arrow on the blade guard. Be sure to tighten the blade shaft arbor nut with the wrench provided. **Be careful not to over tighten.**



**WARNING!** Not dressing the blade frequently or setting the blade too high will cause it to grab the tile possibly causing injury to the operator and the saw. Setting the blade depth too low will cause it to cut into the main table that may result in injury.

12. Check that the blade tracks near the center of the channel in the main table, and that the table moves freely from front to back.

13. Sometimes the material being cut is not abrasive enough to expose new diamonds on the blade. If the blade is not sharpened, it will rub against the surface resulting in heat build up in the core. To prevent this, it is necessary to dress the blade. To dress the blade simply cut something that is very abrasive such as a piece of cement block. Indications that the blade needs dressing includes:

- The diamond in the matrix appear shiny because they are worn flat.
- The blade stops cutting or noticeably slows down.



Blade dressing stones are available from your local Pearl Warehouse.

14. Before using the saw fill the water tub enough to submerge the water pump with clean water only. Replenish as necessary and clean the water tub frequently. Do not operate a wet cutting blade without adequate water flow to both sides of the blade. Never run the pump dry.

15. When cutting, always hold the material firmly lying flat, supported by the main table with one edge resting against the main table backstop.



- Do not attempt to cut pieces too small to safely hold down on the main table.
- Never use the side of the blade to cut or grind with, only cut in a straight line.
- Keep all parts of your body away from the blade and all other moving parts.
- Never touch or try to stop a moving blade with your hand.

16. When cutting dry - always unplug the water pump first. **Never run the pump dry.**

- Do not use a wet cutting blade for dry cutting. Select the proper dry cutting blade for your application.
- Never make long continuous cuts with dry cutting blades. To avoid heat build up, allow the blade to cool, remove the tile and allow the blade to run freely for a few minutes.

**IMPORTANT - If there is any tendency for the saw to tip or move during certain operations, such as when cutting large heavy tile; the saw must be securely fastened to a supporting table.**

17. Make certain all adjusting knobs or locks are tight and engaged in their detents and that movable parts not intended to move during operation are securely locked before making a cut. **Be careful not to over tighten.**

18. Before connecting the machine to a power source check to see that the "On/Off" switch is in the "off" position.

- Make sure the blade is not contacting anything before connecting to a power source and starting the motor.
- Know how to stop the machine quickly in case of an emergency.



## viii. GROUNDING INSTRUCTIONS

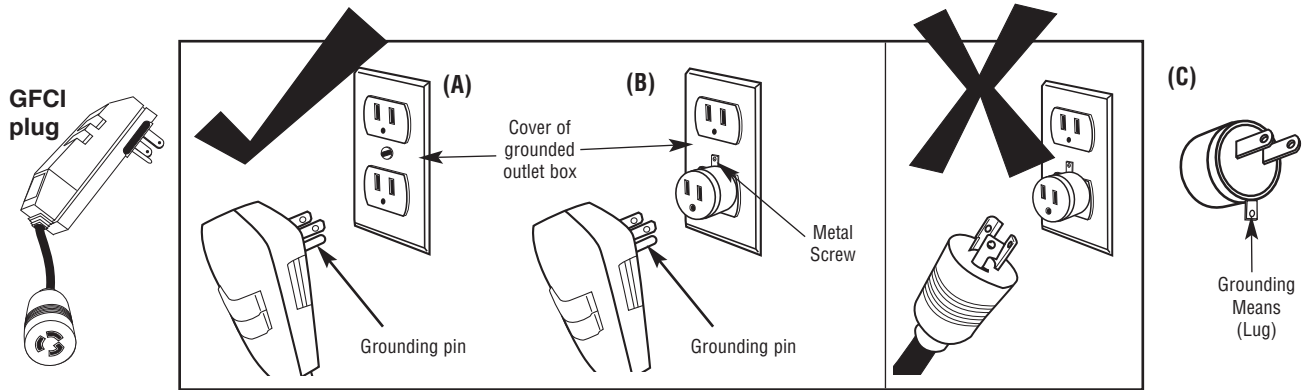


Figure 2

1. Always use the included GFCI plug.
2. In the event of a malfunction or breakdown, grounding provides a path of least resistance for electric current, reducing the risk of electric shock. This tool is equipped with an electric cord which has an equipment-grounding conductor and a grounding plug. The plug must be plugged into a matching outlet that is properly installed and grounded in accordance with all local codes and ordinances.
3. Do not modify the plug provided – it is intended to be used with the included GFCI plug and extension cord. If using an adaptor for a 2-prong outlet, always attach the adaptor to the GFCI plug, never to the power cord.
4. Improper connection of the equipment-grounding conductor can result in a risk of electric shock.
5. Check with a qualified electrician or service person if you do not completely understand the grounding instructions or are unsure that the tool is properly grounded.
6. If an additional extension cord is needed, attach it to the 3-prong GFCI plug. Never use an extension cord longer than 50 feet.

**Always repair or replace a damaged or worn cord immediately.**

7. This saw is intended for use on a circuit that has an outlet that looks like the one illustrated in Figure 2. The GFCI plug used on the saw has a grounding plug that looks like the plug illustrated in Figure 2(A). A temporary adaptor, which looks like the adaptor illustrated in Figures 2(B) and 2(C), may be used to connect the GFCI plug to a 2-pole

receptacle, as shown in Figure 2(B), if a properly grounded outlet is not available. The temporary adaptor should be used only until a properly grounded outlet can be installed by a qualified electrician. The green-colored rigid ear, lug, etc., extending from the adaptor must be connected to a permanent ground, such as a properly grounded outlet box.

**NOTE - Use of a Temporary Adaptor is not permitted in Canada.**

### 8. Position of the Tile Saw.

- To avoid the possibility of the appliance plug or receptacle getting wet, position the tile saw to one side of a wall-mounted receptacle to prevent water from dripping onto the receptacle or plug. The user should arrange a “drip loop” in the cord connecting the saw to a receptacle. The “drip loop” is that part of the cord below the level of the receptacle, or the connector (if an extension cord is used); it prevents water from traveling along the cord and coming into contact with the receptacle. See Figure 3.
- If the plug or receptacle does get wet, do not unplug the cord. Disconnect the fuse or circuit breaker that supplies power to the receptacle. Then unplug and examine for the presence of water in the receptacle.
- If the receptacle is wet, dry it and make certain that the GFCI Plug is reset before



**To reduce the risk of electrocution, keep all connections dry and off the ground. Do not touch plug with wet hands.**

plugging it back into the receptacle. Do not reconnect the fuse or circuit breaker until the receptacle is dry.

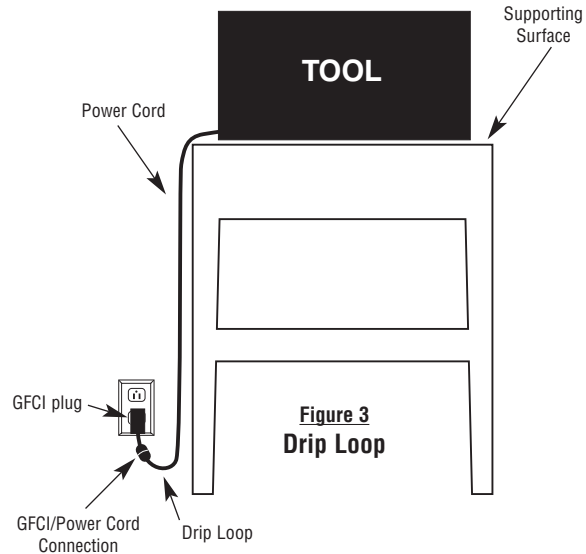
#### 9. Extension Cords

- Always use the extension cord included with the saw.
- If an additional extension cord is needed, use only a cord that is intended for outdoor use. These extension cords are identified by the marking "Acceptable for use with outdoor appliances; store indoors while not in use." Use only extension cords with an electrical rating higher than the rating of the tool. Refer to the chart on page 14. Do not use damaged extension cords. Examine an extension cord before use and replace it if it is damaged. Do not abuse extension cords and do not pull on any cord to disconnect it. Keep the cord away from heat and sharp edges. Always disconnect the extension cord from the receptacle before disconnecting the saw from the extension cord.
- Never use an additional extension cord that is longer than 50 feet.

#### 10. Always use the Ground Fault Circuit Interrupter

(GFCI) plug included with the saw.

11. The tile saw cord includes a 15-amp twist lock plug. Do not modify this plug or use an adaptor on it. This plug is intended to be used with the GFCI Plug included with the saw. The GFCI has a standard 3-prong plug that can be plugged into a standard 3-prong outlet or extension cord.



## ix. USING THE CUTTING TABLE

#### Features:

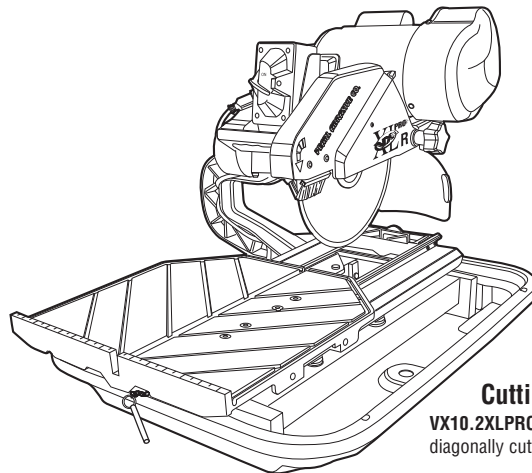
- Cutting table marked in inches for precision cuts.
- 14" cutting table provides more support during larger cutting jobs than the standard 11" cutting tables.

#### Using 90° Rip Guide:

1. Set the rip guide by positioning it on the desired dimension and tighten the threaded knob. Make sure that the rip guide is firmly tightened to avoid slippage. The rip guide can be used for 90° rip cuts from both the left and right side.
2. After the rip guide is positioned for the desired cut, place material flat against the rip guide and the table measurement rail.
3. Simply line-up the material being cut with the appropriate pre-marked lines on the cutting table surface.
4. Now you are ready to make your cut.


#### Making Miter Cuts (Using Optional Miter Block):

1. For miter cuts, place the lip of the miter block on the measurement rail, with the threaded knobs facing you.
2. Tighten the threaded knobs to secure the miter block in place.
3. Place material onto miter block and you are ready to cut.



**Figure 4**  
**Cutting large tile**  
VX10.2XLPROR can cut a 24" tile and diagonally cut a 18" tile.

## X. CARE AND MAINTENANCE

 **WARNING!** For your safety before performing any maintenance on the saw turn off the power switch and unplug the power cord.

The Pearl VX10.2XLPROR requires very little maintenance however, keeping your saw clean and properly adjusted will ensure optimum performance. Take great care not to get water into the motor. Do not use pressure washer to clean motor area.

### 1. Cleaning

- Form a habit of cleaning your saw after each use. To clean the water tub, remove drain plug provided in bottom of tub. Remove saw including water pump from tub. Remove residual water and clean tub using soap and water only. Reinstall saw with pump into tub.
- To increase water pump life remove tile grit by purging water. Pump with fresh water after each use.
- With a damp cloth or sponge wipe clean the guide rails and all other surfaces on the saw where dust and debris has accumulated.

**NOTE - Do not lubricate the guide rails. The presence of oil or grease will cause an accumulation of dust and dirt.**

### 2. Transporting

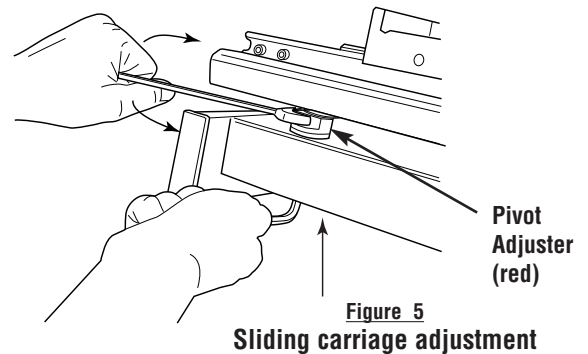
- Unplug the power cord and store it in the empty, dry water tub. For convenience and safety, the saw should be transported with both the main table and carriage **locked**, motor in upper position and all adjustment knobs tightened.

### 3. Sliding Carriage Adjustment

- Make sure that all rails and rollers are clean.
- If carriage and/or table does not slide smoothly, it will require tension adjustment as follows:
  - A. Raise saw 2"-3" from table or workbench (front and rear) gaining access to (red) pivot adjuster bolts. See Figure 5.
  - B. Locate (red) pivot adjuster on frame base. Adjust roller tension against extrusion carriage by loosening socket head bolt

directly below adjuster. See Figure 5.

- C. With bolt loose, turn (red) pivot adjuster



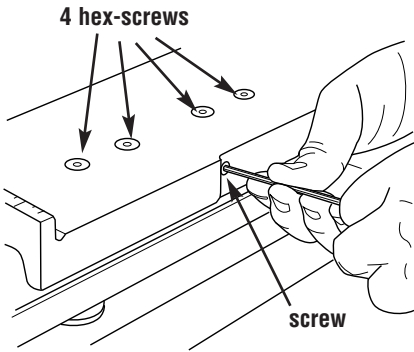
(3/4" wrench is needed) either **counter-clockwise** (putting the roller into the extrusion) or **clockwise** (pulling the roller away from the extrusion.)

- D. Tighten lower hex-bolt when finished.
- E. Since four rollers are adjustable on base, all may need attention at operator's discretion. If the table is not running freely or feels loose, sometimes it is difficult to discern which one needs adjustment. The simplest procedure is to loosen ALL four adjusters and re-adjust in sequential order:
  - a. Right Side Middle
  - b. Right Side Rear
  - c. Right Side Front
  - d. Left Side Middle

Be sure to check for looseness or binding after each roller adjustment.

### 4. Table Roller Adjustment

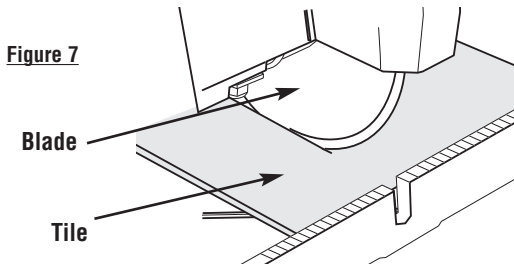
- A. Loosen (4) hex-screws on table top.
- B. Adjust tension on rollers by turning set screw (on outside of table) until desired tension is achieved. **DO NOT OVERTIGHTEN.** See Figure 6.
- C. Re-tighten the (4) screws on table top. Check table movement and re-adjust if necessary. Table should roll free but without side movement.



**Figure 6**  
Table roller adjustment

### 5. Aligning the Blade to the Table

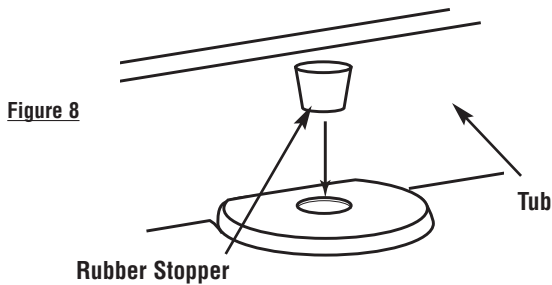
- While cutting, the material being cut must move in a straight line parallel to the saw blade. If the blade is out of plane it will bind at one end of the cut. To align the blade requires cutting a tile (securely against the table back stop) while checking for binding at trailing edge of blade (farthest away from operator). See Figure 7.



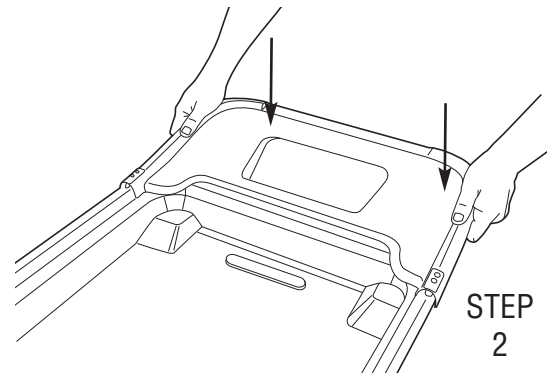
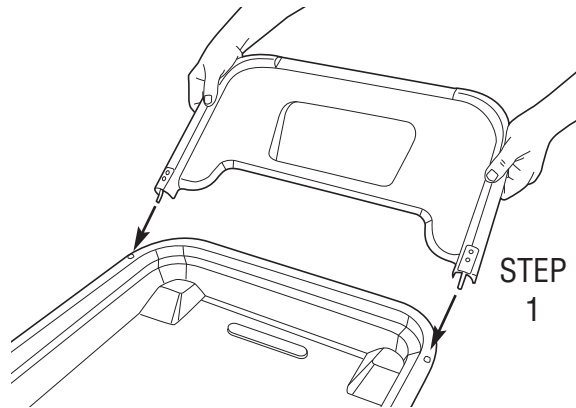
If adjustment is required, loosen four bolts at top of vertical arm. Rotate complete motor assembly as required until alignment is attained. Tighten all four bolts and re-check alignment.

### 6. Tub & Tray

- Insert the large rubber stopper in the drain hole. See Figure 8.

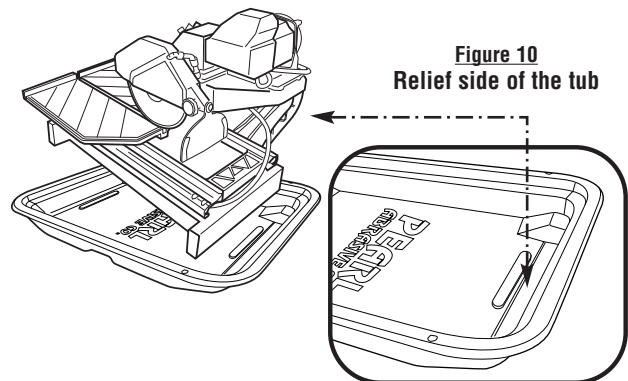


**Figure 9**  
Attaching Drip Tray to Tub



### 7. Positioning the Saw in the Tub

- A. Place the saw in the tub positioning the Vertical Arm on the same side as the relief in the tub shown in Figure 10.



- B. Line the saw up with the molded guides in the base of the tub.

## 8. Connecting the Water Pump

Connect the clear tubing to the pump until it fits securely. See Figure 11.

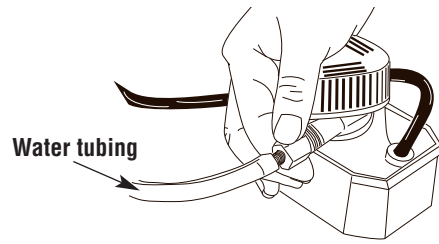


Figure 11

## xi. BEARING HOUSING REPLACEMENT

### To Remove the Bearing Housing:

1. Remove the three screws on the belt guard.
2. Remove the belt guard.
3. Loosen (but do not remove) the adjustment screw behind the mounting plate and the 4 screws on the motor base to remove the belt.
4. Remove the blade lock nut and remove the blade (if there is one present).
5. Remove the 4 screws on the mounting plate closest to the cutting head handle to remove the bearing housing (including the attached pulley and inner flange.)

### To Install the New Bearing Housing:

1. Be sure that you have completed the instructions above to remove the old bearing housing.
2. Open the box and carefully place the flat portion of the new bearing housing face-down on a towel situated on a flat surface.
3. Secure the cutting head in a completely horizontal position.
4. Slide the new bearing housing with the flat portion facing upwards onto the 4 screws

located below the mounting plate. **Take care not to damage the inner flange.** Lock the bearing housing into place by using brackets and nuts.

5. Pull the motor toward you, place the belt on the pulleys, and tighten the motor position adjustment screw. Be sure to leave some slack on the belt.
6. Align the belt by adjusting the motor pulley after loosening the hex screw. **WARNING: Do not adjust the bearing housing pulley.** After aligning the belt, tighten the hex screw.
7. Replace the belt guard and lock into place using 3 screws.

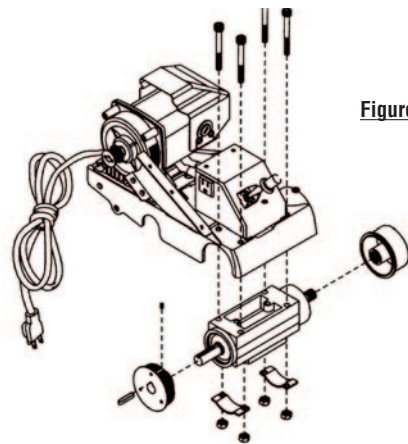


Figure 12

## xii. CUTTING DEPTH

The recommended cutting depth is 1/4" below the cutting table surface. To adjust the cutting depth, loosen the mounting plate adjustment knob so that the blade is 1/4" below the top of the cutting table's surface.

**WARNING: Setting the blade too low may damage the cutting table and if set too high, the blade may grab the material being cut, causing damage and possibly injury.**

BLADE DIAMETER	CUTTING DEPTH
8 inch	2-1/4 inch
9 inch	2-3/4 inch
10 inch	3-1/4 inch

### xiii. BELT REPLACEMENT

1. Turn off the saw before proceeding any further.
2. Loosen and remove the belt guard screws and take off the belt guard.
3. Loosen the 4 nuts (front & back) on the mounting plate.
4. Gently loosen the motor adjustment clip on the very rear of the motor mounting plate.
5. Carefully nudge the motor slightly forward, so there is a little slack in the belt.
6. Take off the old belt and replace with new belt.

7. To re-assemble, follow steps in reverse order.

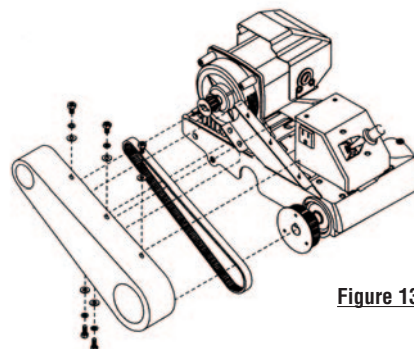
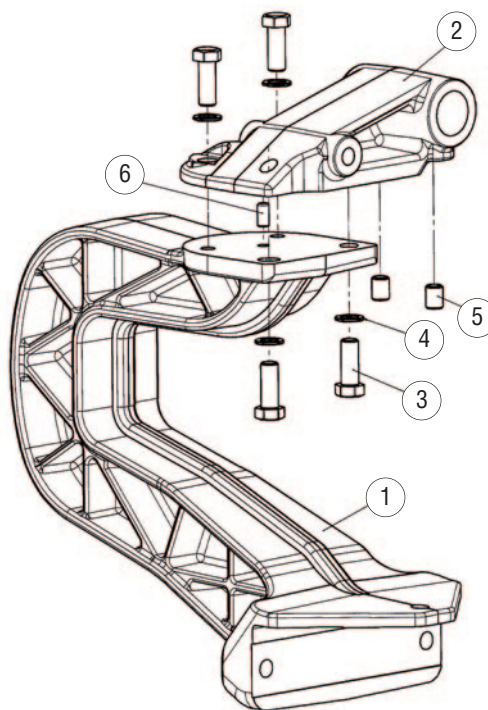


Figure 13

### xiv. REPLACEMENT PARTS LIST

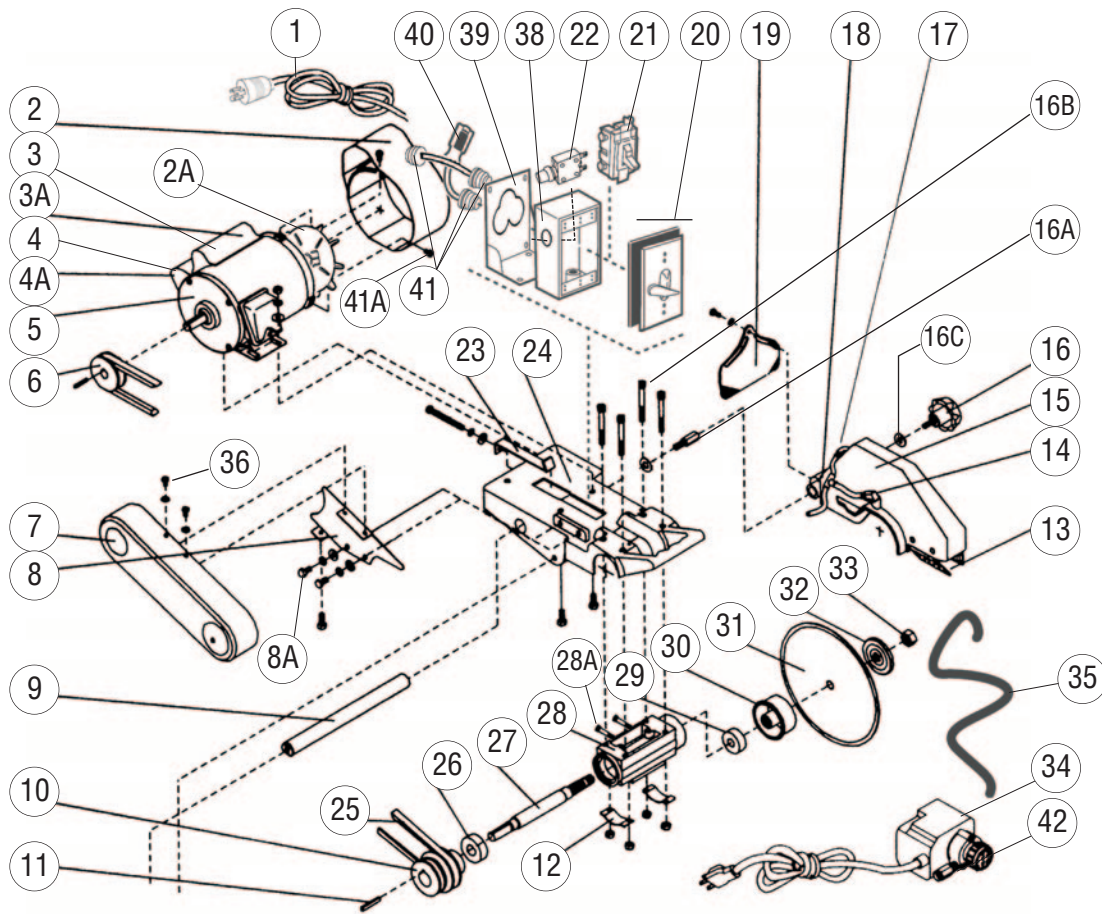
#### VX10.2XLPROR VERTICAL ARM ASSEMBLY



PART NAME	PART NUMBER
1 Arm, Vertical	V380101-MA
2 Mount, Motor 10"	V380201
3 Hex Bolt, .375 - 16x1 Grade 5+	V3800
4 Washer, .375 A.N. Flat .65 O.D. Max.	V3801
5 Set Screw, .375 - 16x.5	V3803
6 Dowel Pin, .250x.5	V3802



# VX10.2XLPROR MOTOR ASSEMBLY

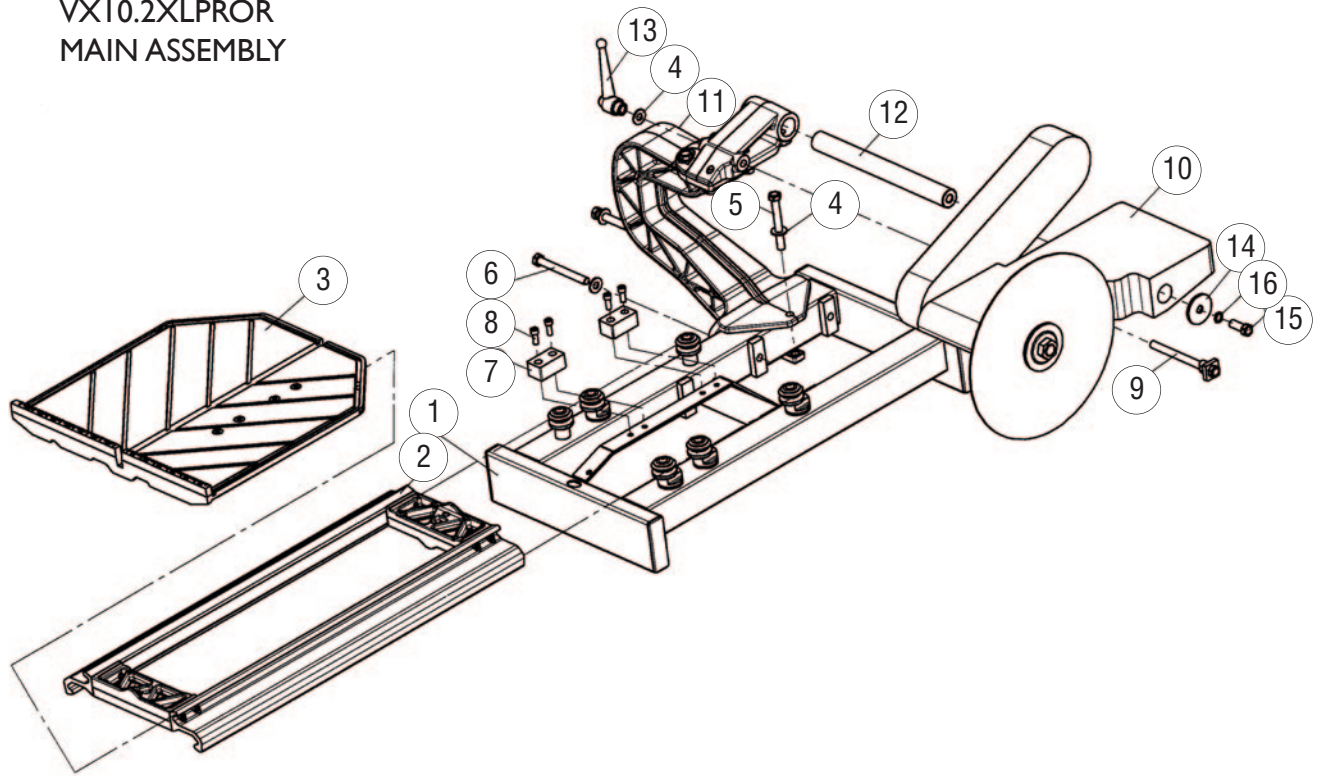


PART NAME	PART NUMBER
1 Power Cable	PSV10010R
2 Motor Fan Cover	PSV10011
2A Motor Fan	PSV10034
3 Running Capacitor	PSV10012
3A Running Capacitor Cover	S800-05.1
4 Starter Capacitor	PSV10013
4A Starter Capacitor Cover	S1000-02.6
5 2 HP Electrical Industrial Motor	PSV10014P
6 Motor Shaft Pulley	PSV10015
7 Belt Guard	PSV10016
8 Belt Guard Bracket	PSV10017
9 Motor Support Shaft	PSV10018
10 Blade Shaft Pulley	PSV10019
11 Pulley Lock Pin	PSV00011
12 Bearing Housing Hold Down Bracket	PSV00009
13 Blade Cleaning Brushes (2 ea.)	PSV10020
14 Water Flow "L" Adapter	PSV00008
15 Blade Guard	PSV10021
16 Blade Guard Adjustment Knob	PSV10022
16A Blade Guard Pivot Screw	S1000-19.1
16B Bearing Housing Screws & Nuts	PSV07038
16C Washer	PSV0310
17 Water Flow "L" Adapter	PSV00008
18 Water Flow "T" Adapter	PSV00005

PART NAME	PART NUMBER
19 Rubber Splash Guard	PSV10023
20 Switch Box Cover with Gasket	PSV0002LR
21 Toggle Switch	PSV00001R
22 Circuit Breaker	PSV10024
23 Motor Adjustment Clip	PSV10025
24 Mounting Plate	PSV10026R
25 #25 Rubber Belt	PSV10027
26 Bearing Attached to Pulley	PSV10028
27 Blade Shaft	PSV00003
28 Liquid Cooled Bearing Housing	PSV000010
28A Water "I" Adapter for Bearing Housing	PSV00710
29 Bearing attached to Inner Flange	PSV10029
30 Inner Flange	PSV10030
31 10" Blade	DTL10HPXL
32 Outer Flange	PSV10031
33 Blade Lock Nut	PSV00004
34 Water Pump	CX38011
35 Water Tubing	PSV00040R
36 Belt Guard Screws (3)	PSV07033
38 Switch Box	PSV00002R
39 Switch Box Bracket	PSV10026R
40 Water Pump Receptacle	PSV10033R
41 Connectors (3)	PSV10032R
42 Intake Pump Screen	CX38019

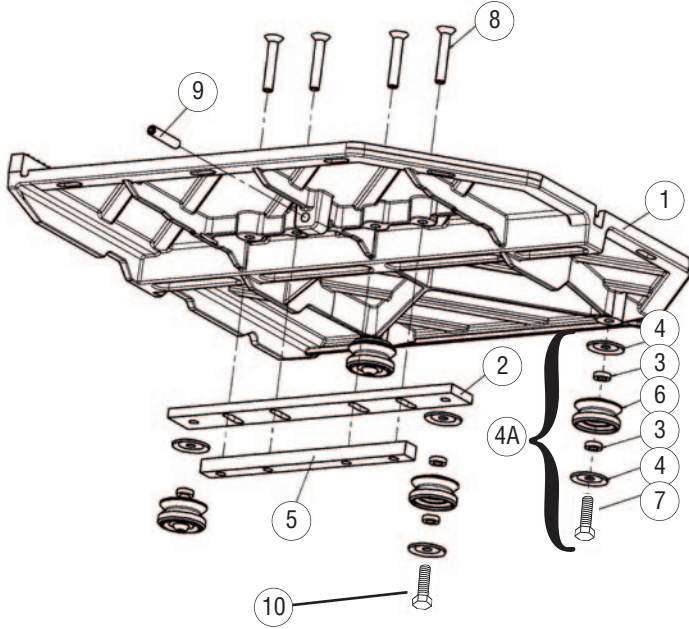


VX10.2XLPROR  
MAIN ASSEMBLY



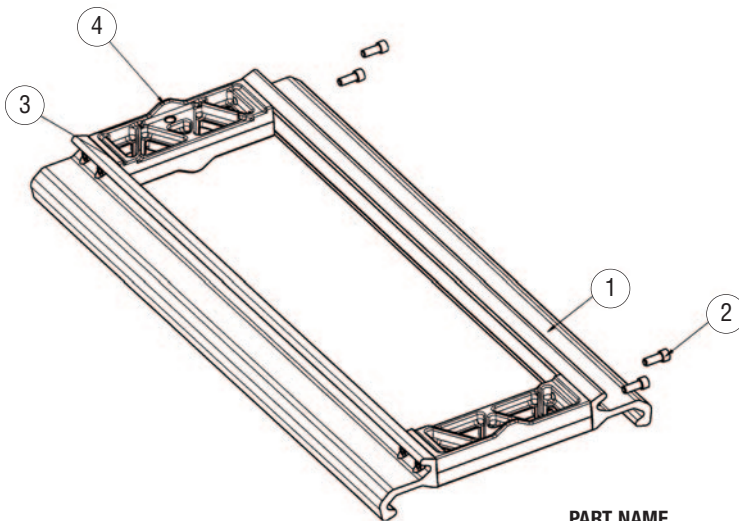
PART NAME	PART NUMBER
1 Base Assembly	V31000
2 Carriage Assembly (Complete)	V31100SS
3 Table Assembly	V380000-M
4 Washer, Flat: .375 SAE	V3809
5 Hex Bolt, Grd. 5 Min., .375 - 16UNCx3	V3806
6 Hex Bolt, Grd. 5 Min., .375 - 16UNCx3.5	V3807
7 Bumper Stop	12142
8 Socket Head Cap Screw, Plated .25 - 20UNC x.625	V3808
9 T-Bolt	V380207
10 10" Cutting Head	V380400
11 Vertical Arm Assembly	V380200
12 Shaft, Pivot	V380202-MA
13 Handle, Adjustable	6270K34
14 Fender Washer, Metric	V3811
15 Bolt, .10mm x 25	V3812
16 Washer, Lock 10mm	V3813

VX10.2XLPROR  
TABLE ASSEMBLY



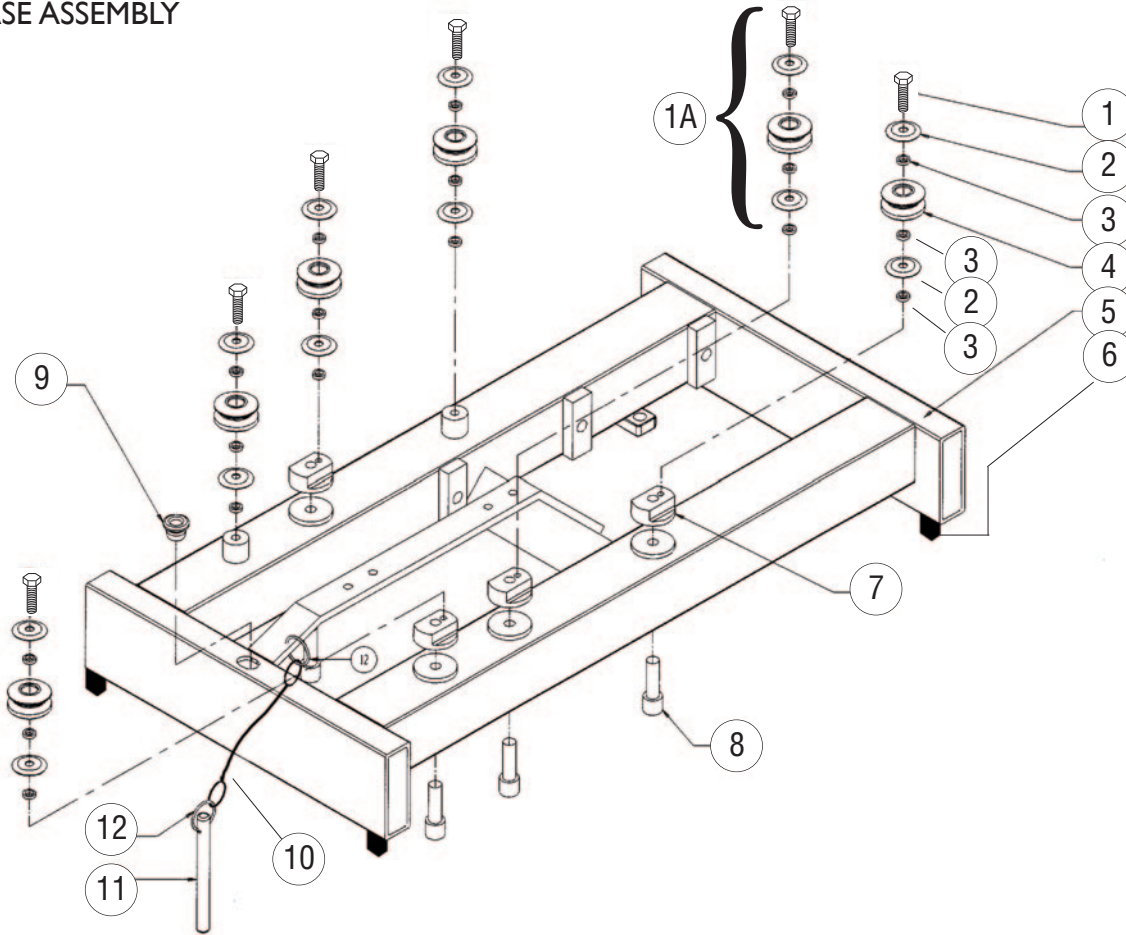
PART NAME	PART NUMBER
1 Table Plan	V380001-MA
2 Mount, Roller	V31014-MA
3 Spacer, Roller	V31004-MA
4A Complete Metal Roller	V31003-SPM
4 Washer, Coined	V31005-MA
5 Nut Plate, Table	V31015-MA
6 PVC Roller	V31003
7 Bolt 1/4"-20UNCx32L	V03051
8 Flat Head Socket, .25-20x1.5	V3815
9 Set Screw, .25-20x1.25	V3816
10 Screw 1/4"-20UNCx27.5L	V03056

VX10.2XLPROR  
CARRIAGE ASSEMBLY



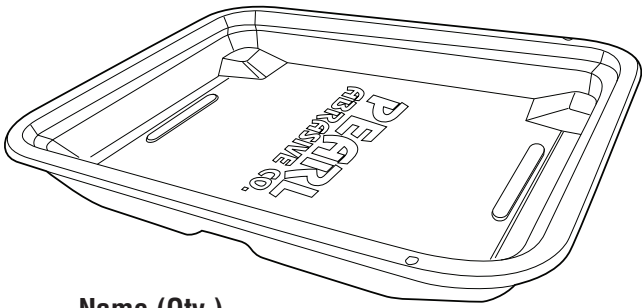
PART NAME	PART NUMBER
1 Rail Guides	V31008SS 10.2PRO Set of 2
2 Screw, Sockethead, 1/4-20x6.2	V3808
3 Shim (Optional)	V31018
4 End Casting	V31009-MA

VX10.2XLPROR  
BASE ASSEMBLY



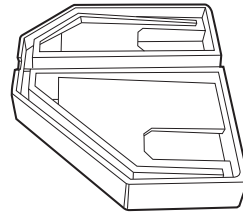
PART NAME	PART NUMBER
1A Complete Metal Roller	V31003-SPM
1 Bolt 1/4''-20UNCx32L	V03051
2 Washer, Coined	V31005-MA
3 Spacer, Roller	V31004-MA
4 Metal Roller (use only with stainless steel rails)	V31003M
5 Base, Sub-Assembly	V31000
6 Rubber Feet for Frame (set of four)	PA00090
7 Pivot, Adjuster	V31002-MA
8 Screw, Sockethead 5/16-18x2	12178
9 Bushing, Pin Lock	V31016-MA
10 Chain	V31017-A
11 Pin, Lock	V31017-B
12 Ring	V31017-C

## xv. ACCESSORIES AND PARTS



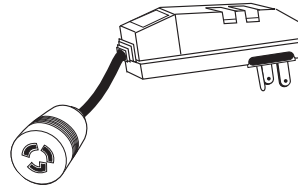
**Name (Qty.)**  
Stainless Steel Water Tray (1)  
Drain plug not included

**Part Number**  
V35012SSXL



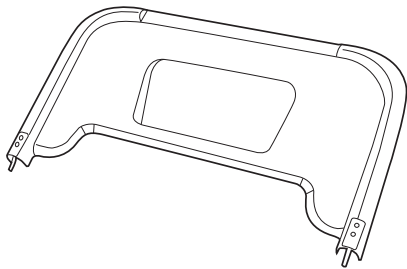
**Optional Name (Qty.)**  
Extension Table (1)

**Part Number**  
V38008



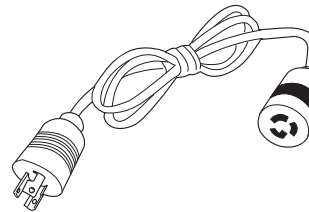
**Name (Qty.)**  
GFCI (1)

**Part Number**  
V35018-REV.A



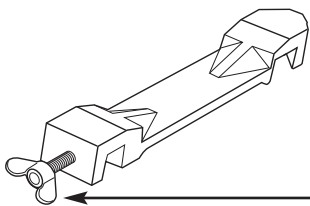
**Name (Qty.)**  
Drip Tray (1)

**Part Number**  
V35011P



**Name (Qty.)**  
Extension Cord (1)

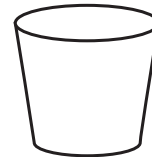
**Part Number**  
V35019



**Name (Qty.)**  
Complete  
45°/90° Rip Guide with Knob (1)

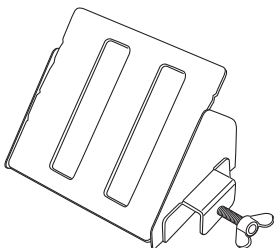
**Part Number**  
V35000

**Knob Only (1)**  
V35016



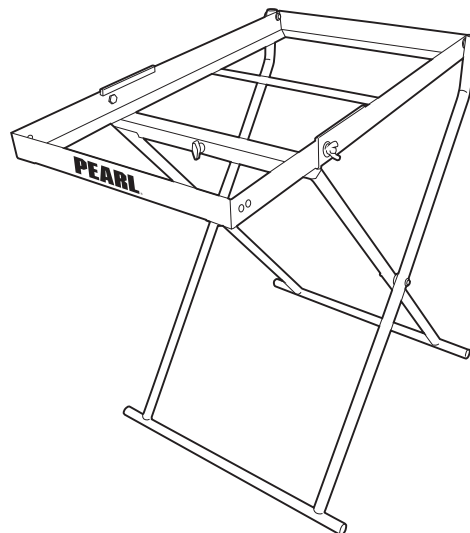
**Name (Qty.)**  
Drain Plug (1)

**Part Number**  
S1000-48



**Optional Name (Qty.)**  
Miter Block (1)

**Part Number**  
S1000-34



**Optional Name (Qty.)**  
Saw Stand (1)

**Part Number**  
V35010-UVXL

## xvi. THE RIGHT BLADE DOES THE RIGHT JOB

For the most effective cutting and blade life always use the recommended Pearl Abrasive Co. blade.

PEARL BLADE SERIES	APPLICATION							
	CERAMIC TILE	EXTRA HARD CERAMIC	PORCELAIN	MARBLE	GRANITE	HARDSTONE	GLASS TILE	MOSAIC METAL TILES
Reactor ADM	○	○	○	○	○	○		○
HPXL Series	○	○	○	○	○	○		
HP Series		○	○		○			
Turbo Mesh		○	○		○	○		
DTLB19 Series	○							
Pro-V Series	○	○	○					
Glass Blade								○
SH Series	○			○				

## xvii. HOW TO ORDER PARTS

Please have the following information ready before calling:

- Serial Number of your Tile Saw
- Model Number of the Tile Saw
- When purchased and where
- Part Description

All parts listed may be ordered from your Local warehouses. If the part is not stocked locally, call our Corporate office and ask for our Customer Service Department. For Technical Support call **1-800-969-5561**. In Canada call **1-800-387-0008**. There is a \$25.00 minimum order.

Return Policy: Return goods for credit or exchange on the basis of the following terms: **(1)** They must be current products; **(2)** Items returned for replacement or refund should be in original cartons and must be accompanied by a packing slip with the following information: Returned Goods Authorization (RGA) number obtainable from Customer Service Department • List of items returned • Reason(s) for return(s) • Copy of original invoice(s); **(3)** Freight charges must be assumed by sender; **(4)** Returning goods are subject to a 15% handling charge to cover our cost of repacking and restocking. All Prices are subject to change without notice.

Disclaimer: Pearl Abrasive Co. reserves the right to make changes or improvements on its products without incurring an additional obligation including any obligation to make corresponding changes or improvements to products previously manufactured or sold. Pearl reserves the right to discontinue products at any time without notice.

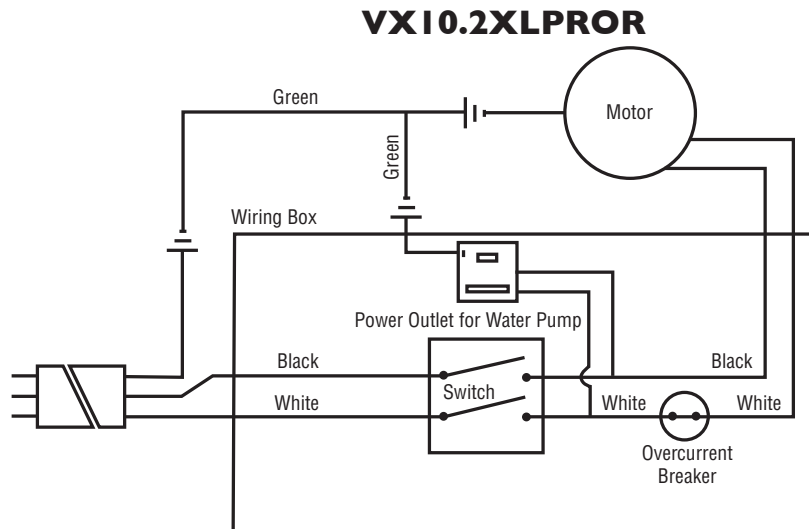
All illustrations displayed in this manual are the property of Pearl Abrasive Co. and shall not be duplicated or reproduced without the express written consent of Pearl Abrasive Co.

## xviii. ELECTRICAL MOTOR SPECIFICATION

<b>VX10.2XLPROR</b>	
<b>Horse Power</b>	2 hp
<b>Volts</b>	115 V/ 60hz
<b>Amps</b>	15 amps
<b>Motor RPM</b>	3420 rpm
<b>Cycle</b>	60
<b>Phase</b>	1
<b>Class</b>	E
<b>Blade Shaft</b>	3200 rpm

### Recommendations:

- It is recommended that a **15 amp circuit** be used while operating this saw. This will prevent possible power interruption or loss.
- Always plug saw as close as possible to the power source while operating. This will allow you to receive optimum electricity.



### WARNING:

To avoid permanent motor damage you must use the correct extension cord. Never use more than one extension cord at a time. Follow the chart for proper size.

<b>LENGTH OF CORD</b>	
<b>WIRE GAUGE</b>	<b>2 hp 115V</b>
No. 12	25'
No. 10	50v
No. 8	75'
No. 6	—

## xix. TROUBLESHOOTING



**WARNING!** For your safety and the safety of others, turn the power switch off and always remove the plug from power source before troubleshooting. Repairs performed by unauthorized personnel could cause serious hazard. We recommend that service to this tool be performed by a qualified service technician with original equipment replacement parts.

**EXCESSIVE NOISE.** Possible blade shaft bearing wear, motor belt loose or motor fan rubbing on housing. Have tool serviced.

**BLADE WILL NOT CUT.** Check for worn out diamond edge. Be sure that the arrow on the blade is rotating the same direction as the motor arbor and/or arrow on the blade guard. Make sure the blade is suitable for the material to be cut. If blade has been used to cut a material that is hard, it may have become dull, dress the blade by cutting a light weight abrasive building block to expose fresh diamonds. Blade dressing stones are available from your local Pearl Warehouse.

**MOTOR WILL NOT START.** Check power supply. If the water pump turns on when the power switch is in the “on” position, but the motor does not, have the motor serviced.

**MOTOR WILL NOT STOP.** The contacts in the switch may have become arched together in the on position, have it serviced.

**MOTOR SHUTS OFF DURING OPERATION.** Check to see that the circuit you are using is not overloaded with lights or other equipment. The fuse or circuit breaker may not have sufficient capacity, use 20-amp power. If you are using an extension cord check the extension cord table to be sure it is heavy enough to carry the current this product will draw. See Page 21 for electric cord reference.

**EXCESSIVE VIBRATION** Check to see that the blade is mounted properly according to safe operating practices section. Blade may be out of balance, try a different blade. Arbor shaft bearings possibly worn, have tool serviced.





## PEARL LIMITED WARRANTY

Every PEARL ABRASIVE CO. tool is thoroughly inspected and tested before leaving the factory. It is warranted to be free of defects in materials and workmanship for a period of ONE YEAR from the date of original purchase. Pearl will repair or (at our opinion) replace a product, or part thereof, found by PEARL ABRASIVE CO. to be defective, provided the defective product is returned to PEARL ABRASIVE CO., freight pre-paid, with proof of purchase.

**RGA NUMBER IS REQUIRED.** Prior to the return of any product or part, a Return Goods Authorization number must be obtained from PEARL ABRASIVE CO. by fax (562) 928-3857 or calling (800) 969-5561. The owner's name, address, phone number, as well as the serial number of the product, proof of purchase, and a brief statement detailing the nature of the claimed defect, are required for authorization.

**This Warranty does not apply where:**

- repairs have been made or attempted by others
- repairs are required because of normal wear and tear
- the tool has been abused, misused or improperly maintained
- alterations have been made to the tool
- the product is used in a manner or with a blade not recommended by the manufacturer

**In no event shall Pearl Abrasive Co. be liable for any indirect, incidental or consequential damages from the sale or use of the equipment. This disclaimer applies both during and after the term of warranty.**

**Pearl Abrasive Co. disclaims liability for any implied warranties, including implied warranties of "merchantability" and "fitness for a specific purpose", after the one year term of this warranty.**

This warranty gives you specific legal rights, and you may also have other rights which vary from state to state. Some states do not allow the exclusion or limitation of incidental or consequential damages, so the above limitation or exclusion may not apply to you. Some states do not allow limitation on how long an implied warranty lasts, so the above limitation may not apply to you.

All parts replaced under warranty will be considered as part of the original product and any warranty on these parts will expire coincidentally with the original product warranty.

This warranty supersedes all previous PEARL ABRASIVE product warranties. **EXCLUSION:** Water pump and motor warranty is through the original equipment manufacturer.

# PEARL®

**CORPORATE OFFICE: SO. CALIFORNIA • USA**

4900 ZAMBRANO ST., COMMERCE, CA 90040

562-927-5561 • FAX 562-928-3857

**Toll Free: 800-969-5561**

**www.pearlabrasive.com**

**GEORGIA • USA**

3950 STEVE REYNOLDS BOULEVARD  
NORCROSS, GA 30093

**ONTARIO • CANADA**

375-2 PIDO ROAD  
PETERBOROUGH, ONTARIO K9J-6X7